

Remote Control Panel

Operating Instructions

Before operating the unit, please read this manual thoroughly and retain it for future reference.



RCP-D50/D51

To prevent fire or shock hazard, do not expose the unit to rain or moisture.

To avoid electrical shock, do not open the cabinet. Refer servicing to qualified personnel only.

Afin d'éviter tout risque d'incendie ou d'électrocution, ne pas exposer cet appareil à la pluie ou à l'humidité.

Afin d'écartier tout risque d'électrocution, garder le coffret fermé. Ne confier l'entretien de l'appareil qu'à un personnel qualifié.

Um Feuergefahr und die Gefahr eines elektrischen Schlages zu vermeiden, darf das Gerät weder Regen noch Feuchtigkeit ausgesetzt werden.

Um einen elektrischen Schlag zu vermeiden, darf das Gehäuse nicht geöffnet werden. Überlassen Sie Wartungsarbeiten stets nur qualifiziertem Fachpersonal.

For the customers in the USA

This equipment has been tested and found to comply with the limits for a Class A digital device, pursuant to Part 15 of the FCC Rules. These limits are designed to provide reasonable protection against harmful interference when the equipment is operated in a commercial environment. This equipment generates, uses, and can radiate radio frequency energy and, if not installed and used in accordance with the instruction manual, may cause harmful interference to radio communications. Operation of this equipment in a residential area is likely to cause harmful interference in which case the user will be required to correct the interference at his own expense.

You are cautioned that any changes or modifications not expressly approved in this manual could void your authority to operate this equipment.

The shielded interface cable recommended in this manual must be used with this equipment in order to comply with the limits for a digital device pursuant to Subpart B of Part 15 of FCC Rules.

For the customers in Europe

This product with the CE marking complies with the EMC Directive (89/336/EEC) issued by the Commission of the European Community.

Compliance with this directive implies conformity to the following European standards:

- EN55103-1: Electromagnetic Interference (Emission)
- EN55103-2: Electromagnetic Susceptibility (Immunity)

This product is intended for use in the following Electromagnetic Environment(s):

E1 (residential), E2 (commercial and light industrial), E3 (urban outdoors) and E4 (controlled EMC environment, ex. TV studio).

Pour les clients européens

Ce produit portant la marque CE est conforme à la Directive sur la compatibilité électromagnétique (EMC) (89/336/CEE) émise par la Commission de la Communauté Européenne.

La conformité à cette directive implique la conformité aux normes européennes suivantes:

- EN55103-1: Interférences électromagnétiques (émission)
- EN55103-2: Sensibilité électromagnétique (immunité)

Ce produit est prévu pour être utilisé dans les environnements électromagnétiques suivants:

E1 (résidentiel), E2 (commercial et industrie légère), E3 (urbain extérieur) et E4 (environnement EMC contrôlé, ex. studio de télévision).

Für Kunden in Europa

Dieses Produkt besitzt die CE-Kennzeichnung und erfüllt die EMV-Richtlinie (89/336/EWG) der EG-Kommission.

Angewandte Normen:

- EN55103-1: Elektromagnetische Verträglichkeit (Störaussendung)
- EN55103-2: Elektromagnetische Verträglichkeit (Störfestigkeit),

für die folgenden elektromagnetischen Umgebungen:

E1 (Wohnbereich), E2 (kommerzieller und in beschränktem Maße industrieller Bereich), E3 (Stadtbereich im Freien) und E4 (kontrollierter EMV-Bereich, z.B. Fernsehstudio).

Table of Contents

Overview	4
Features	4
Locations and Functions of Parts	5
Operation Panel	5
Connector Panel	13
Mounting on a Console	14
Menu Configuration and Basic Menu Operations	15
Basic Operating Procedure	15
Basic Configuration of Menu Display	16
Menu Items with the DXC-D50-Series Cameras	20
Menu Items with the DXC-D30/D35-Series Cameras	27
Menu Items with the DXC-637-Series Cameras	34
Menu Items with the CCU-TX50	38
Initial Settings	45
Setting the Operating Conditions of the RCP-D50/D51 ...	45
Setting the Built-in Clock	45
Adjusting the Buzzer Sound	46
Adjusting the Brightness of the LEDs	47
Changing the Functions of the Rotary Encoders	47
Adjusting the Brightness/Contrast of the LCD	48
Assigning a Function to the ASSIGN Button	48
Specifying the Security Codes	49
File Operations	51
Operating Scene Files	53
Transferring Scene Files between the Camera and a Memory Stick (with the DXC-D50 Series)	54
Operating Setup Files (for DXC-D30/D35 Series only) ...	55
Skin Detail Correction/Skin Matrix Adjustment (for DXC-D30/D35/D50 Series Only)	56
Multi-Camera Control	57
Connections and Preparatons	57
Adjusting the Iris/Master Black of Multiple Cameras at One Time	57
Data Transfer Among Multiple Cameras	57
Operating Multiple Cameras from One RCP Unit — Command Link	58
Memory Sticks	59
Using a Memory Stick	59
Notes on Memory Stick	59
Specifications	61

Overview

The RCP-D50/D51 Remote Control Panel enables remote operation of the DXC-D50-series, DXC-D30/D35-series, or DXC-637-series Color Video Cameras.

The RCP-D50 and RCP-D51 are completely identical in their functions except with respect to the iris and master black adjustments.

For the iris and master black adjustments, the RCP-D50 uses a joystick type control while the RCP-D51 uses rotary knobs.

Features

Optimal control parts arrangement for basic camera operation

This remote control panel is provided with essential control functions for basic operation of a camera. The buttons, knobs, and other controls have been arranged according to their functions and with consideration to their frequency of use. Indicators and buttons light or flash to indicate the status of the system operation. Also, guard frames are provided to protect against accidental use of those buttons vital to camera operation. These features ensure easy and error-free use of this remote control panel.

Full control of shooting operations

Besides controlling camera adjustments and settings, this unit can control tripod operations (pan and tilt) and lens settings (focus and zoom).

Scene file

The unit provides memory to hold data on shooting conditions for 20 different scenes, to enable easy readjustment of the camera for any memorized scenes. (When a DXC-D50-series camera is connected, data are held in memory of the camera.)

Coordination of settings among several cameras

In a system that includes several cameras that are connected via CCUs, connecting the CCUs allows this unit to set up all of the cameras into the same color condition.

Confirmation of camera conditions and operation status

This unit's LCD panel indicates camera conditions such as the optical filter position, value, and lens extender setting. The results of the camera's self-diagnosis tests are also displayed on the LCD panel.

Signal transmission via a digital line

Between this remote control panel and the camera control unit, signals are digitally transmitted via a single connection cable (CCA-7), ensuring a reliable signal. Operating power is also supplied via the cable.

Memory Stick slot

Various data, including scene files, can be stored on a **Memory Stick** and reproduced at any time.

Touch panel with 3¹/₂-inch LCD for various operations

The control panel has a touch panel that permits various items to be selected and adjusted on the LCD in menu format. (The menu items differ among the cameras to be connected.)

Video display function

The LCD can also display pictures from the connected camera, permitting you to use it as a convenient video monitor.

Four units mountable on a 19-inch rack

Up to four units of this control panel can be mounted in a line on a 19-inch EIA standard rack.

Locations and Functions of Parts

Operation Panel

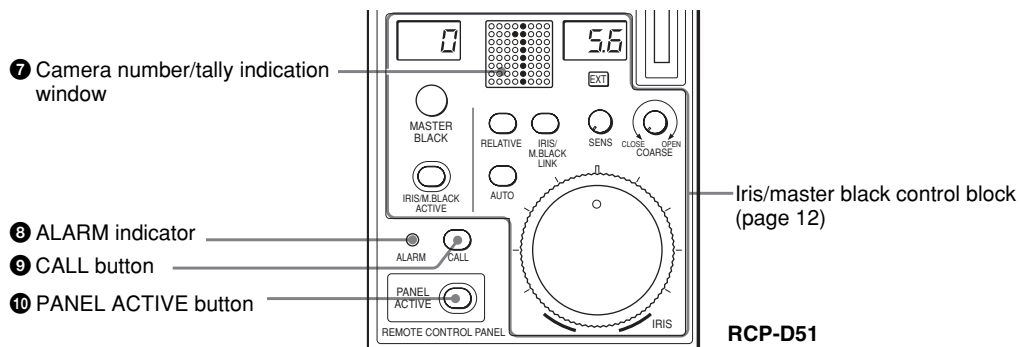
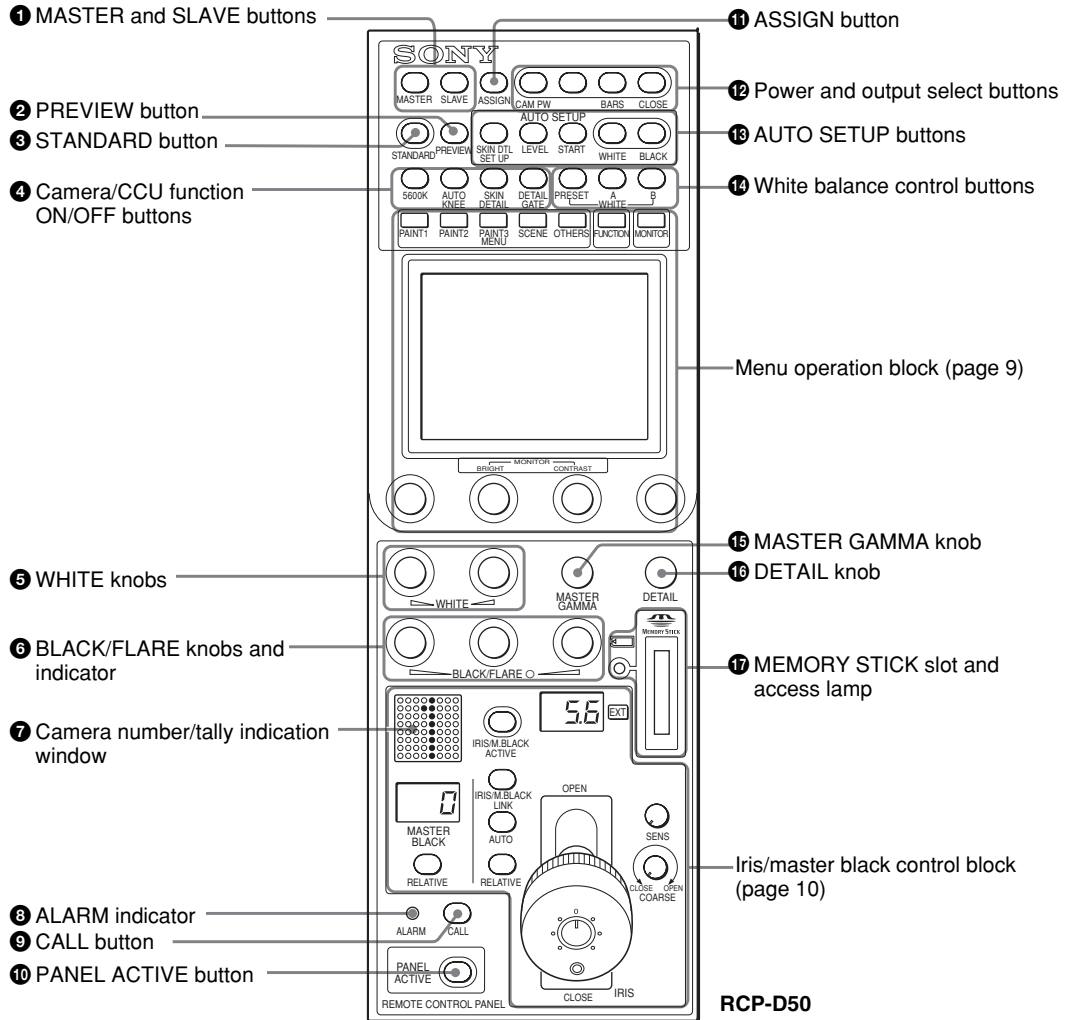

Locations and Functions of Parts

① MASTER and SLAVE buttons

When adjusting the white balance of multiple cameras in Master/Slave mode, designate the master camera or the slave cameras. Press and light up the MASTER button to specify the connected camera for the master. Press and light up the SLAVE button to specify the connected camera for the slave. The slave cameras follow the master camera settings.

If you press a button when lit, it goes dark.

② PREVIEW button

Press this button to control an external device connected to the EXT I/O connector on the connector panel.

For the operational specifications, see “③ EXT I/O (external input/output) connector (9-pin)” in “Connector Panel” on page 13.

③ STANDARD button

When you press this button, the video camera is initialized to its standard state and the button lights for several seconds.

If you press the button while it lights, the video camera retrieves the state before the button was lit.

④ Camera/CCU function ON/OFF buttons

Various functions of the video camera or the CCU can be turned on and off from this panel.

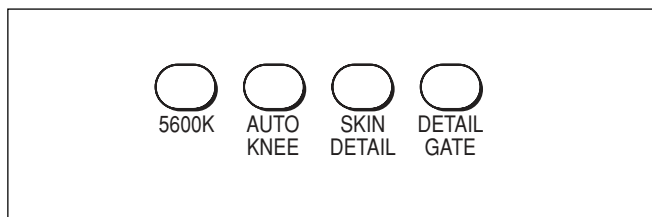

5600K (valid only with the DXC-D50 series):

5600K electric color temperature conversion function

AUTO KNEE: Auto knee function. When this button is lit (ON), the knee point is automatically adjusted according to the light content of the picture.

SKIN DETAIL: Skin detail function

DETAIL GATE: Skin detail gate function. When this button is lit (ON), the adjustment range of the skin tone detail is displayed in white on the monitor screen.

For details on the Skin detail and Skin detail gate, see “Skin Detail Correction/Skin Matrix Adjustment (for DXC-D30/D35/D50-Series Only)” on page 56.

⑤ WHITE (white balance manual adjustment) knobs

Used to manually adjust the white balance.

The left knob is for the R signal and the right knob for the B signal.

⑥ BLACK/FLARE (black balance/flare balance manual adjustment) knobs and indicator

Used to manually adjust the black balance (when the indicator is not lit) or the flare balance (when the indicator is lit).

From the left, the knobs are for R, G, and B signal adjustment.

Selection between black balance and flare balance is made using the OTHERS menu.

See “Changing the Functions of the Rotary Encoders” on page 47.

⑦ Camera number/tally indication window

The number of the camera being controlled from this panel is displayed in orange.

When a red tally signal is sent to the camera, the number is displayed in black and the background of the number lights in red.

When a green tally signal is sent to the camera, the number is displayed in black and the background of the number lights in green.

When both the red and green tally signals are simultaneously sent, the left half of the background lights in red and the right half lights in green.

⑧ ALARM indicator

Lights when trouble occurs in the camera system and the self-diagnostic function activates at the video camera or the CCU.

⑨ CALL button

When the camera is connected via a CCU, press to send a call signal to the video camera, on which the CALL button lights. The tally lamps on the camera and the red tally lamp on the CCU light when not lit, or go dark when lit.

When the CALL button on the video camera is pressed, the CALL button on this panel lights and a buzzer sounds.

⑩ PANEL ACTIVE button

Press and light up the button to permit this panel to control the camera system (Panel active status). The IRIS/M.BLACK ACTIVE button of the iris/master black control block also lights. If you press this button so that it goes dark, the panel will be locked, preventing accidental misoperation. If Panel Active Lock with a security code has been enabled, the PANEL ACTIVE and the IRIS/M.BLACK ACTIVE buttons are locked by pressing the PANEL ACTIVE button for more than 2 seconds in Panel active status.

For details on Panel Active Lock, see “Specifying the Security Codes” on page 49.

⑪ ASSIGN button

Various functions can be assigned to this button using “SW Setting” of the RCP Config menu (No function is assigned at the factory).

To assign a function, see “Assigning a Function to the ASSIGN Button” on page 48.

⑫ Power and output select buttons

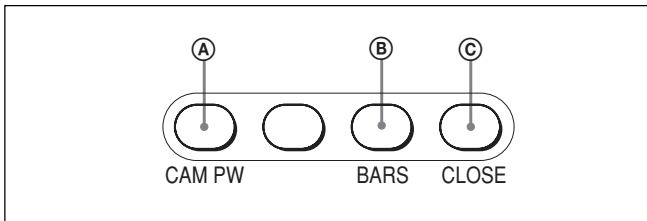

① CAM PW (camera power) button

When the unit is connected to the CCU-TX7, you can turn the power supply to the video camera ON by pressing and lighting up this button. (The button promptly flashes until the camera becomes ready for transmission.)

When you press this button again, it starts flashing and the power supply is turned off.

② BARS (color-bar signal) button

Press and light up this button to activate the color-bar signal generator of the video camera and send the respective the color-bar signal. When you press this button again, the button goes dark and the camera picture is displayed.

⑬ CLOSE button

Press and light the button to close the iris. To release the close mode, press the button again so that it goes dark.

The close mode is also released when you press the STANDARD or IRIS/M.BLACK LINK button, or operate a scene file.

⑭ AUTO SETUP buttons

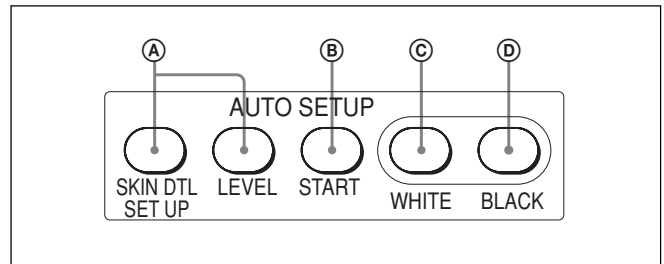

① Auto adjustment item select buttons

Press and light up these buttons to select the items to be automatically adjusted.

SKIN DTL SETUP: Skin detail

LEVEL: Gamma balance, knee point, master black level, etc.

For details on the Skin detail setup, see “Skin Detail Correction/Skin Matrix Adjustment (for DXC-D30/D35/D50 Series Only)” on page 56.

② START button

Press to start automatic adjustment of the selected items.

The button lights during adjustment and goes dark when adjustment is completed.

③ WHITE (white balance) button

Press to automatically adjust the white balance.

The button lights during adjustment and goes dark when adjustment is completed.

④ BLACK (black balance) button

Press to automatically adjust the black balance and black set.

The button lights during adjustment and goes dark when adjustment is completed.

Note

If an error occurs during adjustment, the pressed button flashes.

Locations and Functions of Parts

14 White balance control buttons

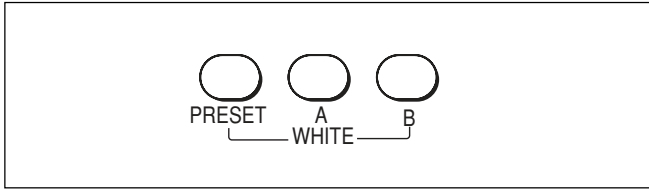

PRESET: Press and light this button to retrieve the preset white balance of the camera.

A (memory A): Press and light this button to retrieve the white balance stored in memory A of the camera.

B (memory B) (valid only with the DXC-D50 series): Press and light this button to retrieve the white balance stored in memory B of the camera.

Note

When the ATW (automatic tracing white balance) function is active, the white balance control buttons are not operative.

15 MASTER GAMMA knob

Used to adjust the master gamma.

16 DETAIL knob

Used to adjust the detail level.

17 MEMORY STICK slot and access lamp

Insert a **Memory Stick** to store setting data, such as reference files and scene files of the video camera or CCU.

The access lamp shows the status of the **Memory Stick**.

Off: No **Memory Stick** is inserted.

Lit in green: There is a **Memory Stick** in the slot. In this condition, you can safely eject the **Memory Stick**.

Lit in red: Data are being read/written. If you eject the **Memory Stick** in this condition, the data are not guaranteed. All the data may be lost.

Note

If “Check Memory Stick” is displayed on the LCD in the menu operation block, check that the **Memory Stick** has sufficient unused storage space or it has been properly formatted.

For details on Memory Sticks, see page 59.

Menu operation block

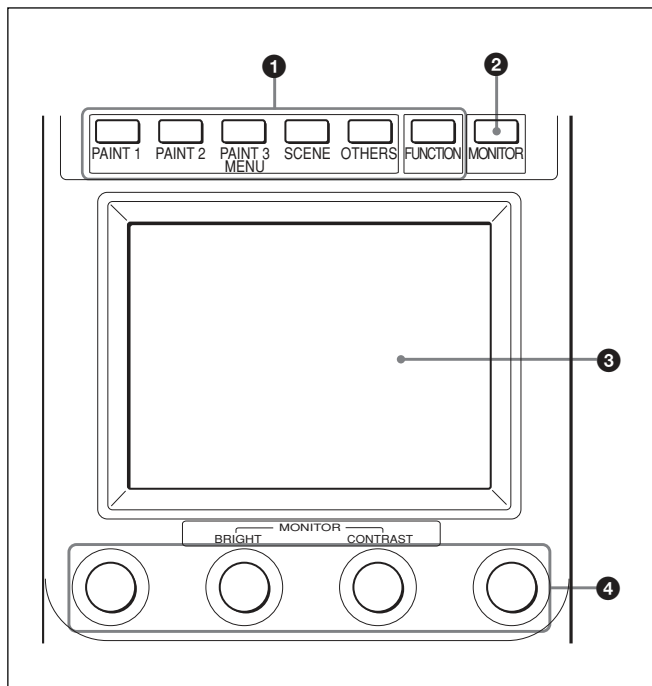

① MENU buttons

Select the menu mode.

If you press and light one of these buttons, the menu for the selected mode appears on the LCD.

PAINT 1/2/3: Each selects the Paint menu to adjust various paint items, such as white, black, and flare. The configuration of the Paint menu depends on the connected camera. When Paint 4 and Paint 5 are available, you can select them by pressing ▲ or ▼ on the Paint menu display (see page 16) or the PAINT 3 button.

SCENE: Selects the File operation menu to register and retrieve scene files.

OTHERS: Selects the OTHERS menu to set various settings, such as operational conditions of this control panel.

FUNCTION: Selects the Function menu to control various camera and CCU functions.

For the items of each menu, see "Menu Configuration and Basic Menu Operations" on page 15.

② MONITOR button

Press this button to display the picture from the connected camera on the LCD.

Press the button again to return to the display of this unit.

With a DXC-D50-series camera connected, each time you press the MONITOR button, the camera picture, the camera picture with characters superimposed, and the menu display of this unit are displayed in sequence (When a CCU is used, the camera picture with characters is not displayed).

If no camera picture is displayed with the CCU-TX7 connected, consult your Sony dealer.

③ LCD/touch panel

Normally displays the statuses (see page 16).

When you press a MENU button, the corresponding menu is displayed to enable you to adjust the displayed items.

When you press the MONITOR button, the picture from the camera is displayed.

④ Control knobs (rotary encoders)

In Menu mode, adjust the selected items on the touch panel.

When the picture from the camera is displayed on the LCD (MONITOR button lit), you can adjust the picture brightness with the second knob (BRIGHT) from the left and the picture contrast with the third knob (CONTRAST) from the left.

Locations and Functions of Parts

Iris/master black control block (RCP-D50)

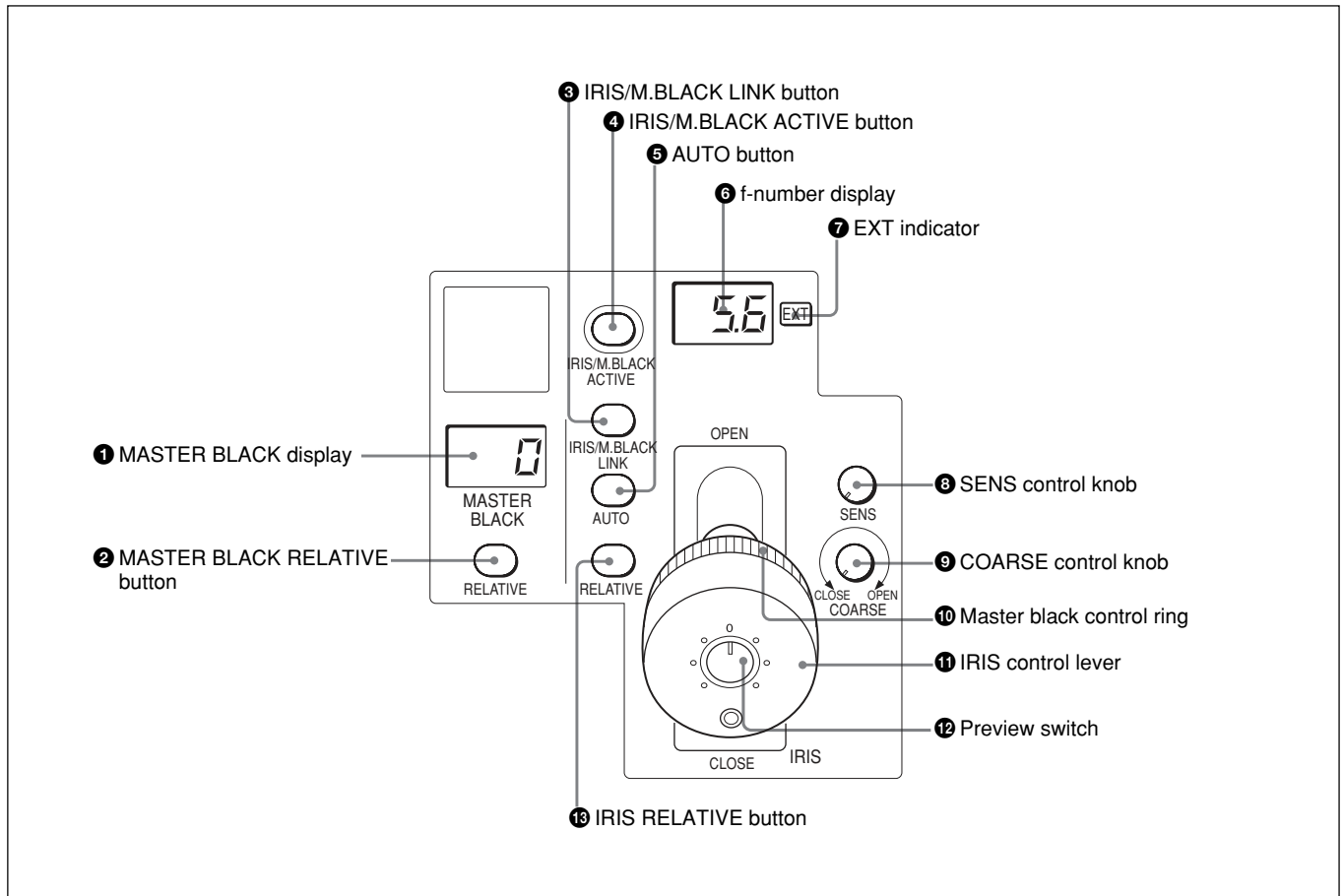

1 MASTER BLACK display

Displays the current master black setting in the range from -99 to +99.

2 MASTER BLACK RELATIVE button

When the IRIS/M.BLACK ACTIVE button is lit, the master black adjustment mode can be selected with this button.

Press and light up the button for Relative mode, or press and turn it dark for Absolute mode.

When the IRIS/M.BLACK ACTIVE button is not lit, Relative mode is automatically selected and this button is not operative.

3

When VR STD MODE is set to Absolute with the VR Setting of the RCP Config menu, Relative mode is not selected even if you turn the IRIS/M.BLACK ACTIVE button off. When you turn the IRIS/M.BLACK ACTIVE button on, the master black value corresponding to the position of the master black control ring is restored.

3 IRIS/M.BLACK LINK (iris/master black adjustment link) button

Press and light up the button to perform linked adjustments of iris and master black for several cameras.

For details, see "Adjusting the Iris/Master Black of Multiple Cameras at One Time" on page 57.

4 IRIS/M.BLACK ACTIVE (iris/master black active) button

Press and light up this button to enable the iris/master black control block of the panel.

When the PANEL ACTIVE button is pressed, this button also lights.

If you press this button so that it goes dark, the panel will be locked, preventing accidental misoperation.

5 AUTO button

Press and light the button to automatically adjust the iris according to the amount of input light.

When this button is lit, the reference value for automatic iris adjustment can be set with the iris control.

If you press the button when lit, it goes dark and manual iris adjustment is enabled.

6 f-number display

Displays the f number of the current iris setting. When the iris is closed, "CL" is displayed.

When the DXC-D50 series is connected, "OP" is displayed for the maximum f-number value.

7 EXT (lens extender) indicator

Lights when the lens extender is used.

8 SENS (sensitivity) control knob

Used for manual iris adjustment in Absolute mode. This control is not operative when Relative mode is selected.

See the table "Iris adjustment functions" to the right.

9 COARSE control knob

Used for manual iris adjustment.

See the table "Iris adjustment functions" to the right.

10 Master black control ring

Turn to manually adjust the master black level.

11 IRIS control lever

When the AUTO button is not lit, you can adjust the iris manually by moving the lever.

When the AUTO button is lit, the reference value for automatic iris adjustment can be set.

See the table "Iris adjustment functions" to the right.

12 Preview switch

Press this switch to control an external device connected to the EXT I/O connector on the connector panel.

For the operational specifications, see "3 EXT I/O (external input/output) connector (9-pin)" in "Connector Panel" on page 13.

13 IRIS RELATIVE (iris relative) button

When the IRIS/M.BLACK ACTIVE button is lit, the iris adjustment mode can be selected with this button.

Press and light up the button for Relative mode or press so that it goes dark for Absolute mode.

When the IRIS/M.BLACK ACTIVE button is not lit, Relative mode is automatically selected and this button is not operative.

Note

When VR STD MODE is set to Absolute with "VR Setting" of the RCP Config menu, Relative mode is not selected even if you turn the IRIS/M.BLACK ACTIVE button off. When you turn the IRIS/M.BLACK ACTIVE button on, the iris setting corresponding to the IRIS lever position is restored.

Iris adjustment functions

	Relative mode (RELATIVE button lit)	Absolute mode (RELATIVE button not lit)
IRIS lever (RCP-D50)/ IRIS control (RCP-D51)	Adjusts the iris with relative values from OPEN to CLOSED. ^{a)}	Adjusts the iris within the variable range set by the SENS and COARSE controls.
COARSE control	Adjusts the total range from OPEN to CLOSED in relative values.	Sets the lower limit for CLOSED.
SENS control	Does not function.	Sets the upper limit for OPEN according to CLOSED value set by the COARSE control.

a) The adjustable range can be set with "VR Rel. Scale" of the RCP Config menu.

Locations and Functions of Parts

Iris/master black control block (RCP-D51)

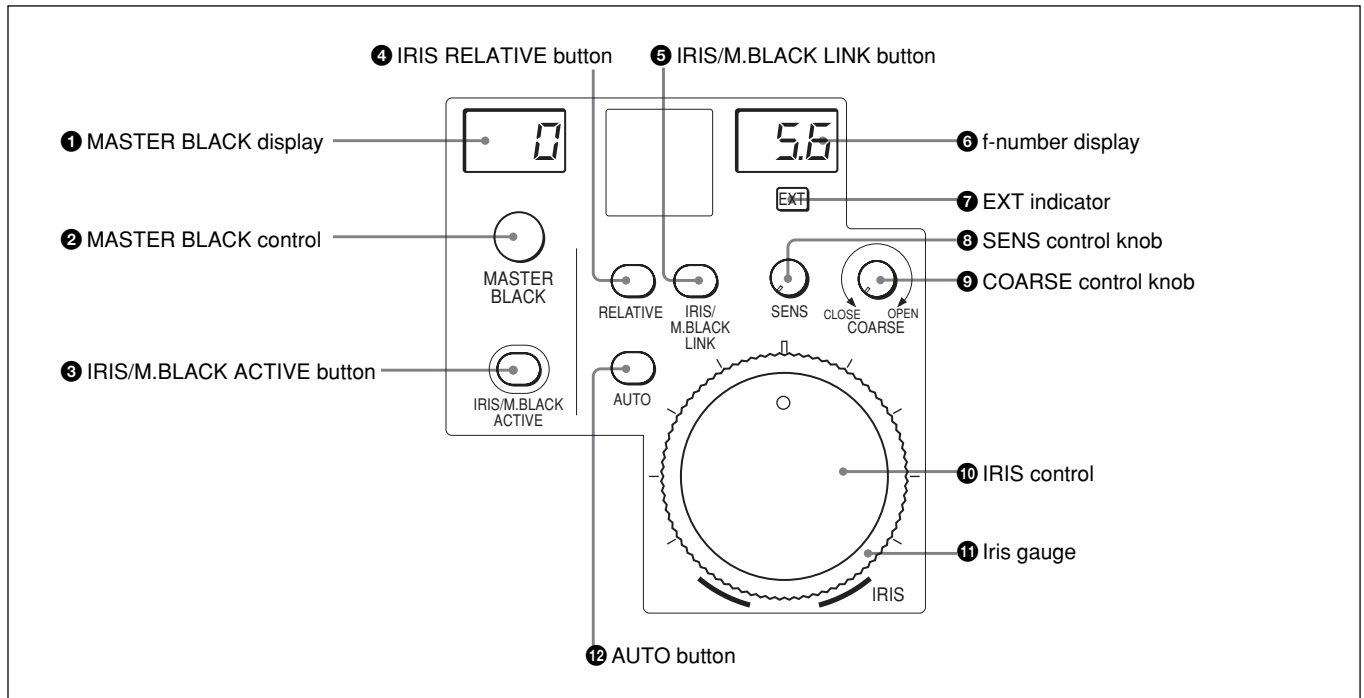

1 MASTER BLACK display

Displays the current master black setting in the range from -99 to +99.

2 MASTER BLACK control

Manually adjust the master black level.
The setting is displayed in the MASTER BLACK display.

3 IRIS/M.BLACK ACTIVE (iris/master black active) button

Press and light up this button to enable the iris/master black control block of the panel.

When the PANEL ACTIVE button is pressed, this button also lights.

If you press this button so that it goes dark, the panel will be locked, preventing accidental misoperation.

4 IRIS RELATIVE (iris relative) button

When the IRIS/M.BLACK ACTIVE button is lit, the iris adjustment mode can be selected with this button. Press and light up the button for Relative mode or press so that it goes dark for Absolute mode.

When the IRIS/M.BLACK ACTIVE button is not lit, Relative mode is automatically selected and this button is not operative.

Note

When VR STD MODE is set to Absolute with “VR Setting” of the RCP Config menu, Relative mode is not selected even if you turn the IRIS/M.BLACK ACTIVE button off. When you turn the IRIS/M.BLACK ACTIVE button on, the iris setting corresponding to the position of the IRIS control is restored.

5 IRIS/M.BLACK LINK (iris/master black adjustment link) button

Press and light up the button to perform linked adjustments of iris and master black for several cameras.

For details, see “Adjusting the Iris/Master Black of Multiple Cameras at One Time” on page 57.

6 f-number display

Displays the f number of the current iris setting. When the iris is closed, “CL” is displayed. When the DXC-D50 series is connected, “OP” is displayed for the maximum f-number value.

7 EXT (lens extender) indicator

Lights when the lens extender is used.

⑧ SENS (sensitivity) control knob

Used for manual iris adjustment in Absolute mode. This control is not operative when Relative mode is selected.

See the table "Iris adjustment functions" on page 11.

⑨ COARSE control knob

Used for manual iris adjustment.

See the table "Iris adjustment functions" on page 11.

⑩ IRIS control

When the AUTO button is not lit, you can adjust the iris manually by turning the control.

When the AUTO button is lit, the reference value for automatic iris adjustment can be set with this control.

See the table "Iris adjustment functions" on page 11.

⑪ Iris gauge

Turn the gauge to set the line to the most frequently used iris position, and it can be used as the reference for manual iris adjustment.

⑫ AUTO button

Press and light the button to automatically adjust the iris according to the amount of input light.

When this button is lit, the reference value for automatic iris adjustment can be set with the iris control.

If you press the button when lit, it goes dark and manual iris adjustment is enabled.

Connector Panel

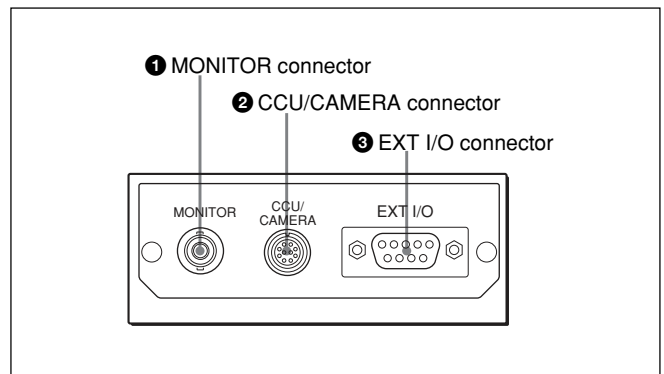

① MONITOR connector (BNC type)

Connect to a video monitor.

② CCU/CAMERA (camera control unit/camera) connector (10-pin)

Connect to the REMOTE connector of a camera control unit or a camera.

③ EXT I/O (external input/output) connector (9-pin)

This connector permits you to control an external device using the PREVIEW button (page 6) or the preview switch (page 11).

Operational specifications

While the PREVIEW button or the preview switch (RCP-D50 only) is held pressed, pin 1 and pin 2 of the EXT I/O connector are short-circuited.

Pin assignment of the EXT I/O connector

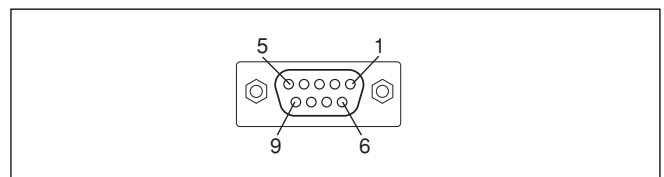

Caution

When installing this panel, provide a gap of 7 cm (3 inches) or more behind the connector panel to prevent damage to cables.

Mounting on a Console

The RCP-D50/D51 can be mounted on a console as shown below:

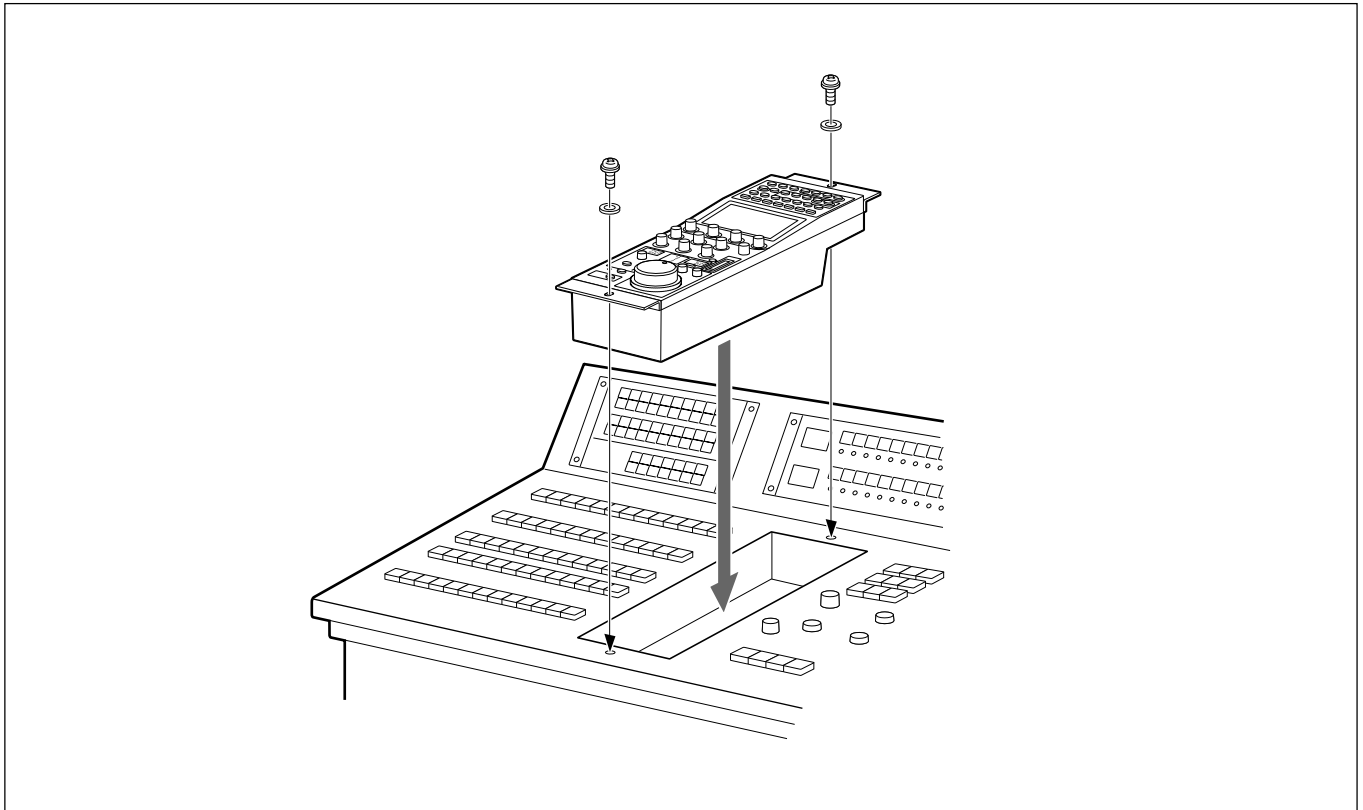

Menu Configuration and Basic Menu Operations

The RCP-D50/D51 provides menu operations for various functions such as adjustments of system equipment.

Basic Operating Procedure

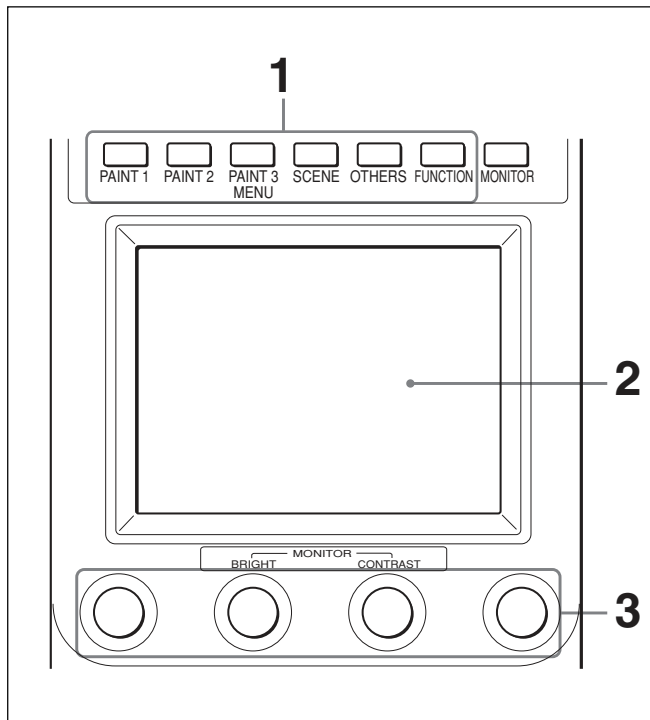

- 1** To display a menu, press and light one of the MENU buttons.

The menu operation mode is initiated and the menu for the pressed button appears on the display.

PAINT 1/2/3: Paint menu

SCENE: Scene file operation menu

OTHERS: OTHERS menu

FUNCTION: Function menu

NOTE

The menu items to be displayed depends on the connected camera.

- 2** Select the item to be adjusted.

Press the button that shows the name of the item on the menu to obtain the corresponding adjustment display or operation area.

When the selected menu is composed of multiple pages

With the menu that is composed of multiple pages such as Paint menu, press ▲ or ▼ to flip the pages. See “Initial display (Paint menu)” on the next page.

When a submenu is shown

Press the desired submenu item to change the display.

See “Submenu” on page 17.

- 3** Set or adjust the item (parameters).

- Turn the control knobs (or press the button) to adjust (or set) the corresponding item (parameters) to the desired values. See “Adjustment display” on page 17.
- When a message is displayed, follow the instruction and press **OK**.

When the adjustment is finished

- To adjust another item of the same menu, press the names of that item.
- To adjust items of another menu, press the corresponding MENU button.
- To release the menu operation mode, press the lit MENU button.
- You may select Function menu without exiting the currently selected menu. When you exit Function menu by either of the following methods, the previous menu is restored.
 - Press the lit FUNCTION button so that it goes dark.
 - Press the lit MENU button for the previous menu.

To monitor the camera picture

Press the MONITOR button.

The picture from the connected camera is displayed on the LCD.

With a DXC-D50-series camera connected, each time you press the MONITOR button, the camera picture, the camera picture with characters superimposed, and the menu display of this unit are displayed in sequence. (When a CCU is used, the camera picture with characters is not displayed.)

Menu Configuration and Basic Menu Operations

Basic Configuration of Menu Display

Status display

When you do not select any menu or the signal from the camera, the LCD shows the following status display:

On the status display, the set value of each item is only displayed. The setting is made with the Function menu or with the corresponding knob on the operation panel.

The set values of the shutter and master gain are displayed. You may adjust these items using the Function menu.

The ND filter number being selected on the camera is displayed.

When you select a scene file, the filename is displayed.

You may adjust these items using the WHITE, MASTER GAMMA, BLACK/FLARE, and DETAIL knobs, and IRIS control (or IRIS lever). The "Black" columns can be changed to "Flare" using the OTHERS menu.

Status			
Shutter	M. Gain	Filter	
60	12dB	1	
Scene File : 2 DXC-D50			
	White	Gamma	Detail
	0	0	0
	Black	Iris	
	0	2	

Initial display (Paint menu)

When you press and light the PAINT 1 (or PAINT 2, PAINT 3) button of the menu operation block, the initial display of the Paint menu is obtained.

Current page number / total number of pages

To clear the adjusted values

The names of the items are displayed. Press the name of the item to be adjusted. The color of the pressed name area will change, and the lower half of the panel will become the adjustment display (see the next page).

Press either to flip the pages of the menu.

Current page number / total number of pages				
1 / 5				
Clear	White	Black	Flare	Gamma /Knee

Adjustment display (Paint menu)

When you select an item on the initial display of the Paint menu, the lower half of the panel becomes the adjustment display for the selected item.

Example: when you select "White" from the PAINT 1 initial display with the DXC-D50 series connected

When you press this, the upper half of the panel becomes the monitor output setting display (see page 19).

The adjustment parameters for the selected item and their adjustment values are displayed.

You may adjust these items using the corresponding control knobs.

If you press a value area after pressing [Clear], that adjustment value is initialized to standard.

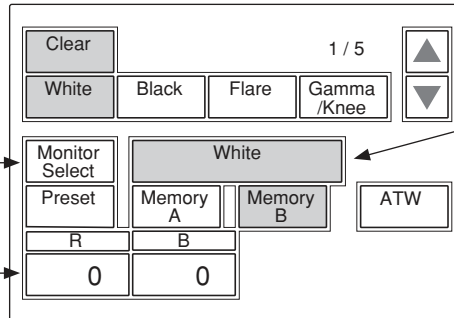

The name of the item selected on the initial display is displayed. If you press this area after pressing [Clear], all the adjustment values for the selected item are initialized to standard.

When there are any ON/OFF functions related to the adjustment, the names of the functions are displayed on this line.

Submenu

If the selected item has many parameters, a submenu is displayed.

Example: when you select "Skin Detail" from the PAINT 2 initial display (Advance mode) with the DXC-D50 series connected

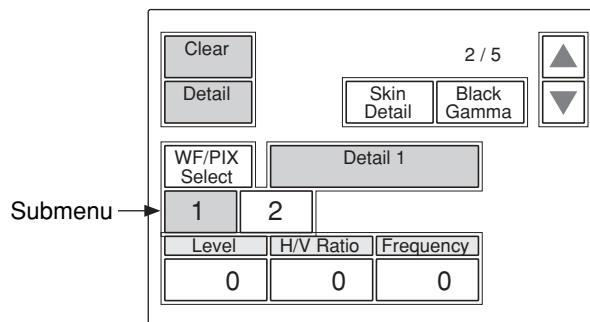

Press to switch the parameters.

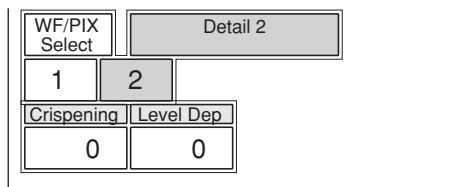

Menu Configuration and Basic Menu Operations

Function menu displays

When you press and light the FUNCTION button of the menu operation block, the scene file operation menu display is obtained.

When “Operation” is selected

Example: with the DXC-D50 series connected

Press one of these buttons calls the adjustment display of the corresponding paint item. The items to be displayed on this Function menu can be changed using the OTHERS menu. (You cannot jump to the items that are not available on the connected camera or disabled.)

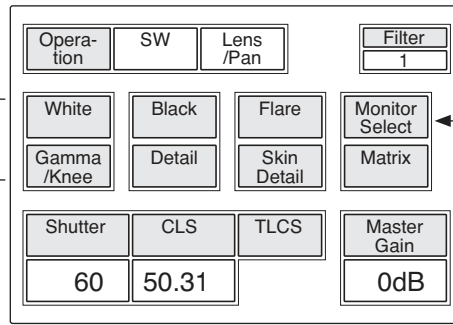

The ND filter number being selected on the camera is displayed.

When you press this, the upper half of the panel becomes the monitor output setting display (see the next page).

You may adjust these items using the corresponding control knobs.

When “SW” is selected

Example: with the DXC-D35 series connected

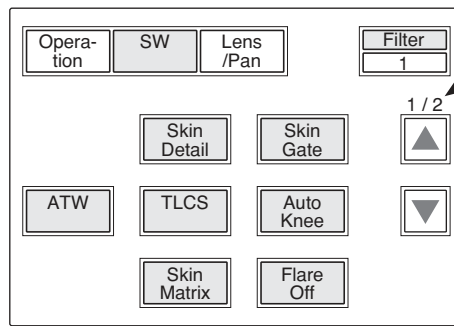

Current page number / total number of pages

Press either to flip the pages of the menu.

These buttons turn on and off the corresponding functions. Any button whose designation includes “Off” turns the respective function OFF when you light it. Other buttons turn the respective functions ON when you light them.

Monitor output set display (Expansion menu)

When you press **Monitor Select** on an adjustment display of the Paint menu, the upper half of the panel becomes the monitor output setting display.

Press again to return to the previous display.

When the CCU-TX7 is connected, you can select the WF/PIX output signals.

- R/G/B:** To independently select the R, G, or B signal.
- RGB:** To select the R, G, and B signals in combination.
- SEQ:** Only the WF output is enabled, and you can monitor the waveforms of the R, G, and B signals in sequence.
- ENC (encode):** The encoded signal is output.

Scene File operation menu display

When you press and light the SCENE button of the menu operation block, the Scene File operation menu display is obtained.

Scene file recall buttons:
Buttons 1 to 20 can be displayed by pressing ▲ or ▼, or turning the leftmost (Page) control knob.

Store ← Scene file store button

File list

Scene : 2* ← Filename box:
Enter a filename using the second (Char) from the right and the rightmost (Cur) control knob.

For details on the scene file operations, see page 53.

Menu Configuration and Basic Menu Operations

Menu Items with the DXC-D50-Series Cameras

The “Control items” marked with ● are those assigned to the control knobs. The other items are operated on the menu display.

The items displayed differ according to whether the unit is in Advanced Setting mode or in Normal Setting mode. The items shaded () in the table below are displayed only in Advanced Setting mode. Switching between Normal Setting mode and Advanced Setting mode is performed in RCP Config (Security → Status) on the OTHERS menu.

Paint menu (with the DXC-D50 series)

Paint menu consists of pages 1 to 5. You can select page 1 through 3 directly by pressing the MENU buttons, PAINT 1, PAINT 2, or PAINT 3. Pressing ▲ or ▼ of the page selected with a MENU button flip pages 1 through 5 in sequence.

Paint 4 and 5 can also be selected in sequence by pressing the PAINT 3 button.

Page	Menu	Submenu	Control item	Function
Paint 1	White		White Preset	To retrieve the white balance settings preset by the camera
			Memory A	To retrieve the white-balance settings stored in Memory A. The retrieved settings can be adjusted in Auto or Manual mode (the adjusted values are stored in Memory A).
			Memory B	To retrieve the white-balance settings stored in Memory B. The retrieved settings can be adjusted in Auto or Manual mode (the adjusted values are stored in Memory B).
			ATW	To turn ON/OFF the Auto Tracing White function (which automatically adjusts the white balance when lighting conditions change)
			● R	To adjust the gain of the R signal in the white when Memory A or Memory B is pressed
			● B	To adjust the gain of the B signal in the white when Memory A or Memory B is pressed
	Black		● R	To adjust the gain of the R signal in the black
			● B	To adjust the gain of the B signal in the black
			● Master	To adjust the master black
	Flare		Flare Off	To turn the flare (black level when flare is generated) correction function ON/OFF
			● R	To adjust the amount of flare correction for the R signal
			● G	To adjust the amount of flare correction for the G signal
		● B	To adjust the amount of flare correction for the B signal	
	Gamma/Knee		Auto Knee	To turn the Auto Knee circuit ON/OFF
			● Gamma	To adjust the gamma level
			● Blk Gamma	To adjust the black gamma level
			● Knee Point	To adjust the level at which the knee correction starts. As the value becomes larger, the start level decreases, which enhances the knee correction effects.
			● Knee Slope	To adjust the knee slope (amount of knee correction)

Page	Menu	Submenu	Control item	Function
Paint 2	Detail	Detail 1	• Level	To adjust the detail (contour correction) level
			• H/V Ratio	To adjust the ratio of V (Vertical) detail to H (Horizontal) detail in detail correction. As the value becomes larger, the V detail ratio increases.
			• Frequency	To adjust the boost frequency (thickness of contour lines) for the detail correction
		Detail 2	• Crispening	To adjust the crispening level (appropriate level at which details of noise signals are removed)
			• Level Dep	To adjust the level dependence (level at which the detail signal starts being suppressed)
	Cross Color		• CCS Level	To adjust the cross color suppress level to suppress the phenomenon of color jittering or coloring when a minutely striped pattern is shot
	Skin Detail		Detail Gate	To turn ON/OFF the skin gate area (target color range of skin detail correction or skin matrix adjustment)
			Skin DTL	To turn the skin detail function (which suppresses the contour correction in the selected area) ON/OFF
			Auto Skin	The unit will go to Standby mode when this button is pressed, and will automatically start obtaining the skin gate area data when Start is pressed.
			• Level	To adjust the amount of skin detail correction. As the value becomes larger, the amount of detail in the skin gate area decreases.
			• Phase	To adjust the color phase of the designated area
			• Width	To adjust the color width of the designated area
			• Sat	To adjust the color saturation of the designated area
	Black Gamma		• R	To adjust the level of the black R gamma
• B			To adjust the level of the black B gamma	
• Master			To adjust the master black gamma	
Paint 3	Knee/DL		Auto Knee	To turn the auto knee ON/OFF
			• Point	To adjust the level at which the knee correction starts. As the value becomes larger, the start level decreases, which enhances the knee correction effects.
			• Slope	To adjust the knee slope (amount of knee correction)
			Gamma	
	• B	To adjust the level of the B gamma		
	• Master	To adjust the master gamma		
	Matrix	Matrix 1	• Hue	To adjust the hue of the linear matrix
			• Sat	To adjust the color saturation of the linear matrix
			• Matrix	To select the Matrix Adjustment mode STD: Standard FL: For shooting under fluorescent light High Sat: High saturation (increasing the saturation of primary colors)
		Matrix 2	• R-G/• G-B/• B-R	To adjust the color tone for the R-G, G-B, or B-R elements of the matrix
			• Matrix	To select the Matrix Adjustment mode
		Matrix 3	• R-B/• G-R/• B-G	To adjust the color tone for the R-B, G-R, or B-G elements of the matrix
			• Matrix	To select the Matrix Adjustment mode
	Skin Matrix		Skin Matrix	To select the skin matrix function ON/OFF
			• Hue	To adjust the hue of the designated area
			• Sat	To adjust the color saturation of the designated area

Menu Configuration and Basic Menu Operations

Page	Menu	Submenu	Control item	Function
Paint 4	White Clip		• Master	To adjust the amount of white clip (the highest white level). As the value becomes larger, the output level decreases.
			TLCS	To turn the TLCS (total level control) function ON/OFF
	TLCS		• AGC/C.Point	To set the f-stop value (f-2, f-2.8, f-4, or f-5.6) at which the iris control is switched to AGC (auto gain control)
			• AGC/Limit	To set the upper limit value for the AGC (3 dB/6 dB/9 dB/12 dB/18 dB) adjustment
			• AE/C.Point	To set the f-stop value (f-5.6, f-8, f-11, or f-16) at which the iris control is switched to the AE (auto exposure)
			• AE/Limit	To set the upper limit value for AE control (100/150/200/250)
	Auto Iris		STD	To select the standard auto iris mode
			Spot Light	To select the auto iris mode for shooting spot-lit subjects
			Back Light	To select the auto iris mode for shooting back-lit subjects
	CLS/EVS		TLCS	To turn the TLCS (total level control) function ON/OFF
			Shutter	To turn the shutter function ON/OFF
			CLS	To turn the CLS (clear scan) function (which reduces noise on the horizontal scan lines when the monitor screen connected to a PC is shot) ON/OFF
			EVS	To turn the EVS mode (which reduces flicker by increasing the vertical resolutions) ON/OFF
			• Shutter	To select the shutter speed
			• CLS	To adjust the CLS frequency
Paint 5	Low Key Sat		• Level	To adjust the low key saturation level
	Auto Knee		Adaptive	To turn ON/OFF the function that makes the knee correction slope smooth to make the gradation natural

Function menu (with the DXC-D50 series)

Menu	Control item	Function
Operation	Jump menu 1	To jump to the adjustment screen designated for Menu 1 in Menu Set ^{a)} (Default: White of Paint 1)
	Jump menu 2	To jump to the adjustment screen designated for Menu 2 in Menu Set ^{a)} (Default:Black of Paint 1)
	Jump menu 3	To jump to the adjustment screen designated for Menu 3 in Menu Set ^{a)} (Default: Flare of Paint 1)
	Jump menu 4	To jump to the adjustment screen designated for Menu 4 in Menu Set ^{a)} (Default: Gamma/Knee of Paint 1)
	Jump menu 5	To jump to the adjustment screen designated for Menu 5 in Menu Set ^{a)} (Default: Detail of Paint 2)
	Jump menu 6	To jump to the adjustment screen designated for Menu 6 in Menu Set ^{a)} (Default: Skin Detail of Paint 2)
	Jump menu 7	To jump to the adjustment screen designated for Menu 7 in Menu Set ^{a)} (Default: Matrix of Paint 3)
	Shutter	To turn the shutter function ON/OFF
	• Shutter	To select the shutter speed
	CLS	To turn the CLS (clear scan) function ON/OFF
	• CLS	To select the CLS frequency
	TLCS	To turn the TLCS (total level control) function ON/OFF
	• Master Gain	To select the master gain value among -3/0/3/6/9/12/18/24/30/36 dB
SW	5600K	To turn the color temperature 5600K ON/OFF
	Skin Detail	To turn the skin detail function ON/OFF
	Detail Gate	To turn ON/OFF the display for the skin detail gate area (target color range for the skin detail correction or the skin matrix adjustment)
	ATW	To turn the ATW (auto tracing white balance) function (which automatically adjusts the white balance when lighting conditions change) ON/OFF
	TLCS	To turn the TLCS (total level control) function ON/OFF
	Auto Knee	To turn the Auto Knee function ON/OFF
	Skin Matrix	To turn the skin matrix function ON/OFF
	Flare Off	To turn the flare correction function ON/OFF (OFF while the button is lit)
Lens/Pan ^{b)}	Option 1	To turn the option control function 1 ON/OFF
	Option 2	To turn the option control function 2 ON/OFF
	• Focus ^{c)}	To adjust the focus
	• Zoom ^{c)}	To adjust the zoom
	• Pan ^{d)}	To adjust panning of the tripod head
	• Tilt ^{d)}	To adjust tilting of the tripod head

a) The submenu “Menu Set” can be selected from Security of RCP Config on the OTHERS menu.

b) The item “Lens/Pan” is displayed when Pan/Tilt Enable is set to ON with Security of RCP Config on the OTHERS menu.

c) To control the lens from this unit, the optional focus zoom servo unit and the interface unit for the camera adapter and lens are required.

d) To control the tripod head from this unit, an electric tripod head and the interface unit for the camera adapter and tripod head are required.

Menu Configuration and Basic Menu Operations

OTHERS menu (with the DXC-D50 series)

Menu	2ndary menu	Submenu	Control item	Function
Adjusting	White Shading		• R	To adjust the V white shading (vertical variation of the white) of the R signal
			• G	To adjust the V white shading of the G signal
			• B	To adjust the V white shading of the B signal
Camera Config	Camera ID		CAM ID IND	To turn the camera ID display ON/OFF while the camera is in Color Bars mode
			Clock IND	Switching of the clock indication Cam: To always display the clock indication Bars: To display only when the camera color bars are displayed Off: No clock indication
			• Char	To select characters when entering a camera ID (alphanumerics, symbols, and space)
			• Cur	To move the cursor when entering a camera ID (eight characters)
			ID SET	To register the entered camera ID
	Center Marker		Center Marker	To turn the center marker ON/OFF
			Safety Zone	To set the safety zone (90%/80%/OFF)
	Screen Mode ^{a)}		Screen Mode	To select the Screen mode (4:3/16:9)
	Diag		Req	To request camera's self-diagnostic data (available only when any abnormality has been detected during self-diagnosis)
			Reset	To erase the camera's self-diagnostic data
			• Sel	To display the data read from the camera in order (No display when no abnormality has been detected during self-diagnosis)
	Bars		Bars Type	To select the type of color-bar signals: SMPTE(SPLIT)/SNG/FF 75%/FF 100%
	File	Scene Trans		CAM->MS
			MS->CAM	To transfer a scene file (from the Memory Stick to the camera)
Copy to Slave				To copy the status of the master unit to slave units
RCP Config	RCP Adjusting	Buzzer Volume	• Call	To set the volume of the call buzzer
			• Touch	To set the responding sound volume of the touch panel
			• Switch	To set the confirmation sound volume of the self-illuminating switches
			• Master	To set the total buzzer sound volume
			Call Buzzer	To turn the call buzzer ON/OFF
			Touch Click	To turn the responding sound of the touch panel ON/OFF
			SW Click	To turn the confirmation sound of switches ON/OFF
			All Off	To turn the volume of all the buzzers ON/OFF
	LED Bright	• Switch	To set the brightness of respective LEDs	
		• Tally		
		• Other		
		• Master		To set the brightness of the all LEDs of the unit
	RE Setting		BLACK/FLARE	To select the function for the BLACK/FLARE knob Black: Black balance adjustment Flare: Flare balance adjustment
VR Setting		VR STD Mode	To select the initial settings for IRIS or MASTER BLACK adjustment mode: Absolute or Relative	
		VR Rel. Scale IRIS VR	To select the response rate of the IRIS knob (relative-value adjustment rates: 1/1, 1/2, and 1/4, where 1/1 is the quickest response position)	

a) The item "Screen Mode" is displayed when Screen Md Enable is set to ON with Security of RCP Config on the OTHERS menu.

Menu	2ndary menu	Submenu	Control item	Function
RCP Config (cont.)	VR Setting (cont.)		M. Black VR	(Only available for RCP-D50) To select the response rate of the MASTER BLACK knob (relative-value adjustment rates: 1/1, 1/2, and 1/4, where 1/1 is the quickest response position)
		Information		To display the software version of the unit
	Cable Comp		Cable Length	To set the length of the remote cable (5 m/25 m/50 m)
	SW Setting		• SW Assign/Sel	To allocate a function to the ASSIGN button No Assign: No assignment Black/Flare: Switching the function of the BLACK/FLARE knobs Black Auto: ON/OFF of the auto black (Not operative) ATW: ON/OFF of the auto tracing white balance TLCS: ON/OFF of the total level control function DynaLatitude: ON/OFF of the DynaLatitude function (Not operative)
	CAM No.		CAM ID->No.	To switch the display of the camera number/tally indication of the unit between camera ID and camera number
			• No.	To select the camera number to be displayed on the RCP
	Date/Time Set	Date	• Year	Date adjustment of the clock built into the unit
			• Month	
			• Day	
			Set	
		Time	• Hour	Time adjustment of the clock built into the unit
			• Minute	
			• Second	
Set				
Comm Link		Gain	To turn ON/OFF command link operation (activation of several cameras at the same time) of the gain	
		Shutter	To turn ON/OFF command link operation of shutter settings	
		R/B White	To turn ON/OFF command link operation of the white R/B adjustment	
		R/B Black	To turn ON/OFF command link operation of the black R/B adjustment	
		R/G/B Flare	To turn ON/OFF command link operation of the flare R/G/B adjustment	
Comm Type		Protocol Type ^{a)}	To set the connection mode P Type 2: When connected to DXC-D35, DXC-D50, CCU-TX7, CCU-D50, DSR-300/370/390/500/570 P Type 7: When connected to CCU-TX50	

a) Be sure to power off the camera system and then power it on again after changing the “Protocol Type” setting.

Menu Configuration and Basic Menu Operations

Menu	2ndary menu	Submenu	Control item	Function
RCP Config (cont.)	Security	Engineer Mode		To set whether to display “Status”, “Menu Set”, and “Code No.” or not (With Engineer Mode ON, all operative menu items are displayed regardless of the Advance Mode setting.)
		Status ^{a)}	Advance Mode	To switch between the Normal Setting mode and Advanced Setting mode of the menu
			Screen Md Enable	To set whether switching between 4:3 and 16:9 is enabled or not
			Pan/Tilt Enable	To set whether panning/tilting adjustment is enabled or not
			Power On Active	To specify the Panel Active and Iris/Master Black Active statuses when the unit is started up Full Active: To set the unit to the Panel Active status when started up IRIS/M.Black: To set the unit to the Iris/Master Black Active status when started up Lock: To set the unit to the Panel Lock status when started up Keep state: To set the unit to the previous state when started up
			Panel Active Lock	To set whether to use the Panel Active Lock function with a security code or not. Disable: Not to use the Panel Active Lock function Enable: To use the Panel Active Lock function by specifying a new security code Enable (Engineer Code): To use the Panel Active Lock function with the same security code as that for Engineer Mode
			Code Change	To change the security code for Panel Active Lock (displayed only when a security code for Panel Active Lock has been set)
		Menu Set ^{a)}	To select an item to be displayed on the function menu. Select the number (1-7) using • Cur, and select the item with • Sel: White, Black, Flare, Gamma/Knee, Detail, Cross Color, Skin Detail, Black STR, Black Gamma, Knee/DL, Gamma, Matrix, Skin Matrix, White Clip, TLCS, Auto Iris, CLS/EVS, Auto Knee, Low Key Sat, no jump	
		Code No. ^{a)}	Code No.	To enable/disable the security code setting for Engineer Mode
			Code Change	To change the security code for Engineer Mode (displayed only when a security code for Engineer Mode has been set)
LCD	LCD Brightness/Contrast	• Bright	To set the brightness of the LCD of the unit	
		• Cont	To set the contrast of the LCD of the unit	
LCD Moni.	LCD Monitor Brightness/Contrast	• Bright	To set the brightness of the LCD of the unit when displaying the camera picture	
		• Cont	To set the contrast of the LCD of the unit when displaying the camera picture	
Memory Stick	Memory Stick	Format	To perform formatting of the Memory Stick	

a) The items “Status,” “Menu Set,” and “Code No.” are displayed only in Engineer Mode.

Menu Items with the DXC-D30/D35-Series Cameras

The “Control items” marked with ● are those assigned to the control knobs. The other items are operated on the menu display.

The items displayed differ according to whether the unit is in Advanced Setting mode or in Normal Setting mode. The items shaded () in the table below are displayed only in Advanced Setting mode. Switching between Normal Setting mode and Advanced Setting mode is performed in RCP Config (Security → Status) on the OTHERS menu.

Paint menu (with the DXC-D30/D35 series)

Paint menu consists of pages 1 to 4. You can select page 1 through 3 directly by pressing the MENU buttons, PAINT 1, PAINT 2, or PAINT 3. Pressing ▲ or ▼ of the page selected with a MENU button flip pages 1 through 4 in sequence.

Paint 4 can also be selected by pressing the PAINT 3 button.

Page	Menu	Submenu	Control item	Function
Paint 1	White		White Preset	To retrieve the preset white balance settings in the camera
			Auto	To select the auto white balance adjustment mode
			Manual	To select the manual white balance adjustment mode
			ATW	To turn ON/OFF the Auto Tracing White function (which automatically adjusts the white balance when lighting conditions change)
		● R		To adjust the gain for the R signal in the white when Manual is pressed
		● B		To adjust the gain for the B signal in the white when Manual is pressed
	Black		Auto	To select the auto black balance adjustment mode
			Manual	To select the manual black balance adjustment mode
		● R		To adjust the gain of the R signal in the black
		● B		To adjust the gain of the B signal in the black
		● Master		To adjust the master black
	Flare		Flare Off	To turn the flare (black level when flare is generated) correction function ON/OFF
		● R		To adjust the amount of flare correction for the R signal
		● G		To adjust the amount of flare correction for the G signal
		● B		To adjust the amount of flare correction for the B signal
	Gamma/Knee		DL	To turn ON/OFF the DynaLatitude function (for automatically setting the contrast between the bright and dark areas by detecting the levels of the subject in these areas)
			Knee Preset	To turn ON/OFF the mode that uses the preset knee correction value
			Auto Knee	To turn the Auto Knee circuit ON/OFF
		● Gamma		To adjust the gamma level
		● Knee Point		To adjust the level at which the knee correction starts. As the value becomes larger, the start level decreases, which enhances the knee correction effects.
● Knee Slope			To adjust the knee slope (amount of knee correction)	

Menu Configuration and Basic Menu Operations

Page	Menu	Submenu	Control item	Function
Paint 2	Detail	Detail 1	• Level	To adjust the detail (contour correction) level
			• H/V Ratio	To adjust the ratio of V (vertical) detail to H (horizontal) detail in detail correction. As the value becomes larger, the V detail ratio increases.
			• Frequency	To adjust the boost frequency (thickness of contour lines) for the detail correction
			• V-Limit	To adjust the limit value for vertical detail
		Detail 2	• Crispening	To adjust the crispening level (appropriate level at which details of noise signals are removed)
			• Level Dep	To adjust the level dependence (level at which the detail signal starts being suppressed)
			• High L.	To adjust the amount of suppression of highlight detail (detail added to a high-luminance area)
			• AFT GAM	To adjust the amount of detail added after gamma correction
		Detail 3	Aperture	To turn the aperture correction ON/OFF
			Knee Apert	To turn ON/OFF the detail correction to the level higher than the knee point
			• Aperture	To adjust the amount of aperture correction
			• Knee Apert	To adjust the amount of detail correction to the level higher than the knee point
		Cross Color		Comb Filter R
			Comb Filter G	To turn the green comb filter in the detail circuit ON/OFF. If OFF is selected, clarity improves, but cross color increases.
			• CCS Level	To adjust the cross color suppress level to suppress the phenomenon of color jittering or coloring when a minutely striped pattern is shot
	Skin Detail	Skin Detail 1	Detail Gate	To turn ON/OFF the skin gate area (target color range of skin detail correction or skin matrix adjustment)
			Skin DTL	To turn the skin detail function (which suppresses the contour correction in the selected area) ON/OFF
			Auto Skin	The unit will go to Standby mode when this button is pressed, and will automatically start obtaining the skin gate area data when Start is pressed.
			• Level	To adjust the amount of skin detail correction. As the value becomes larger, the amount of detail in the skin gate area decreases.
			• Size	To adjust the R-Y and B-Y ranges of the skin gate area (for setting each range to the same value at the same time)
			• R-Y	To adjust the R-Y range of the skin gate area
			• B-Y	To adjust the B-Y range of the skin gate area
		Skin Detail 2	Skin Gate	To turn the display of skin gate area ON/OFF
Skin DTL			To turn the skin detail function ON/OFF	
Auto Skin			The unit will go to Standby mode when this button is pressed, and will automatically start obtaining the skin gate area data when Start is pressed.	
• Level			To adjust the skin detail level	
• Posi			To adjust the R-Y and B-Y position of the skin detail gate area (for setting each range to the same value at the same time)	
• R-Y			To adjust the R-Y position of the skin detail gate area	
• B-Y			To adjust the B-Y position of the skin detail gate area	

Page	Menu	Submenu	Control item	Function		
Paint 2 (cont.)	Black STR	Black Stretch 1	• Level	To adjust the black stretch level		
			• Stretch Level/Point 1	To adjust the upper limit of the signal levels that activate the black stretch function		
			• Stretch Level/Point 2	To adjust the lower limit of the signal levels that activate the black stretch function		
		Black Stretch 2	• Level	To adjust the black stretch level		
			• Compress Level/Point 1	To adjust the upper limit of the signal levels that activate the black compress function		
		• Compress Level/Point 2	To adjust the lower limit of the signal levels that activate the black compress function			
Paint 3	Knee/DL		DL	To turn ON/OFF the DynaLatitude function (for automatically setting the contrast between the bright and dark areas by detecting the levels of the subject in these areas)		
			Knee Preset	To turn ON/OFF the mode that uses the preset knee correction value		
			Auto Knee	To turn the Auto Knee function ON/OFF		
			• DL	To select the level of the DynaLatitude effects (Low/STD/High)		
			• Point	To adjust the level at which the knee correction starts. As the value becomes larger, the start level decreases, which enhances the knee correction effects.		
			• Slope	To adjust the knee slope (amount of knee correction)		
			Gamma		• Master	To adjust the master gamma
					Init 3.5	To set the value of the initial part of the gamma curve for low brightness to 3.5
					Init 4.0	To set the value of the initial part of the gamma curve for low brightness to 4.0
					• R	To adjust the level of the R gamma
	• B	To adjust the level of the B gamma				
	Matrix	Matrix 1	Matrix Off	To turn the matrix ON/OFF		
			• Hue	To adjust the hue of the linear matrix		
			• Sat	To adjust the color saturation of the linear matrix		
		Matrix 2	• R-G/• G-B/• B-R	To adjust the color tone for the R-G, G-B, or B-R elements of the matrix		
		Matrix 3	• R-B/• G-R/• B-G	To adjust the color tone for the R-B, G-R, or B-G elements of the matrix		
		Skin Matrix		Skin Matrix	To select the skin matrix function ON/OFF	
	• Hue			To adjust the hue of the designated area		
	• Sat			To adjust the color saturation of the designated area		
	Paint 4	White Clip		• Master	To adjust the amount of white clip (the highest white level). As the value becomes larger, the output level decreases.	
TLCS			TLCS	To turn the TLCS (total level control) function ON/OFF		
			• AGC/C.Point	To set the f-stop value (f-2, f-2.8, f-4, or f-5.6) at which the iris control is switched to AGC (auto gain control)		
			• AGC/Limit	To set the upper limit value for the AGC (3 dB/6 dB/9 dB/12 dB/18 dB) adjustment		
			• AE/C.Point	To set the f-stop value (f-5.6, f-8, f-11, or f-16) at which the iris control is switched to the AE (auto exposure)		
Auto Iris			STD	To select the standard auto iris mode		
			Spot Light	To select the auto iris mode for shooting spot-lit subjects		
			Back Light	To select the auto iris mode for shooting back-lit subjects		
			AI	To select the intelligent auto iris mode ^{a)}		

a) Only with models with the AI function

Menu Configuration and Basic Menu Operations

Page	Menu	Submenu	Control item	Function
Paint 4 (cont.)	CLS/EVS		TLCS	To turn the TLCS (total level control) function ON/OFF
			Shutter	To turn the shutter function ON/OFF
			CLS	To turn the CLS (clear scan) function (which reduces noise on the horizontal scan lines when the monitor screen connected to a PC is shot) ON/OFF
			EVS	To turn the EVS mode (which reduces flicker by increasing the vertical resolutions) ON/OFF
			• Shutter	To select the shutter speed
			• CLS	To adjust the CLS frequency

Function menu (with the DXC-D30/D35 series)

Menu	Submenu	Control item	Function
Operation		Jump menu 1	To jump to the adjustment screen designated for Menu 1 in Menu Set ^{a)} (Default: White of Paint 1)
		Jump menu 2	To jump to the adjustment screen designated for Menu 2 in Menu Set ^{a)} (Default:Black of Paint 1)
		Jump menu 3	To jump to the adjustment screen designated for Menu 3 in Menu Set ^{a)} (Default: Flare of Paint 1)
		Jump menu 4	To jump to the adjustment screen designated for Menu 4 in Menu Set ^{a)} (Default: Gamma/Knee of Paint 1)
		Jump menu 5	To jump to the adjustment screen designated for Menu 5 in Menu Set ^{a)} (Default: Detail of Paint 2)
		Jump menu 6	To jump to the adjustment screen designated for Menu 6 in Menu Set ^{a)} (Default: Skin Detail of Paint 2)
		Jump menu 7	To jump to the adjustment screen designated for Menu 7 in Menu Set ^{a)} (Default: Matrix of Paint 3)
		Shutter	To turn the shutter function ON/OFF
		• Shutter	To select the shutter speed
		CLS	To turn the CLS (clear scan) function ON/OFF
		• CLS	To select the CLS frequency
		TLCS	To turn the TLCS (total level control) function ON/OFF
		• Master Gain	To select the master gain value among -3/0/3/6/9/12/18/18+DPR/24/24+DPR/HYPER Gain
SW	Page1	Skin Detail	To turn the skin detail function ON/OFF
		Detail Gate	To turn ON/OFF the display for the skin detail gate area (target color range for the skin detail correction or the skin matrix adjustment)
		ATW	To turn the ATW (auto tracing white balance) function (which automatically adjusts the white balance when lighting conditions change) ON/OFF
		TLCS	To turn the TLCS (total level control) function ON/OFF
		Auto Knee	To turn the Auto Knee function ON/OFF
		Skin Matrix	To turn the skin matrix function ON/OFF
		Flare Off	To turn the flare correction function ON/OFF (OFF while the button is lit)
	Page 2	Knee Aperture	To turn ON/OFF the detail correction to the level higher than the knee point
		Aperture	To turn the aperture correction ON/OFF
		DL	To turn ON/OFF the DynaLatitude function (for automatically setting the contrast between the bright and dark areas by detecting the levels of the subject in these areas)
		White Clip Off	To turn the white clip function ON/OFF (OFF while the button is lit)
		Detail Off	To turn the detail adjustment function ON/OFF (OFF while the button is lit)
		Gamma Off	To turn the gamma adjustment function ON/OFF (OFF while the button is lit)
		Matrix Off	To turn the linear matrix adjustment function ON/OFF (OFF while the button is lit)

a) The submenu "Menu Set" can be selected from Security of RCP Config on the OTHERS menu.

Menu	Submenu	Control item	Function
Lens/Pan ^{a)}		Option 1	To turn the option control function 1 ON/OFF
		Option 2	To turn the option control function 2 ON/OFF
		• Focus ^{b)}	To adjust the focus
		• Zoom ^{b)}	To adjust the zoom
		• Pan ^{c)}	To adjust panning of the tripod head
		• Tilt ^{c)}	To adjust tilting of the tripod head

a) The item “Lens/Pan” is displayed when Pan/Tilt Enable is set to ON with Security of RCP Config on the OTHERS menu.

b) To control the lens from this unit, the optional focus zoom servo unit and the interface unit for the camera adapter and lens are required.

c) To control the tripod head from this unit, an electric tripod head and the interface unit for the camera adapter and tripod head are required.

OTHERS menu (with the DXC-D30/D35 series)

Menu	2ndary menu	Submenu	Control item	Function	
Adjusting	White Shading		• R	To adjust the V white shading (vertical variation of the white) of the R signal	
			• G	To adjust the V white shading of the G signal	
			• B	To adjust the V white shading of the B signal	
Camera Config	Camera ID		CAM ID IND	To turn the camera ID display ON/OFF while the camera is in Color Bars mode	
			Clock IND	Switching of the clock indication Cam: To always display the clock indication Bars: To display only when the camera color bars are displayed Off: No clock indication	
			• Char	To select characters when entering a camera ID (alphanumerics, symbols, and space)	
			• Cur	To move the cursor when entering a camera ID (eight characters)	
			ID SET	To register the entered camera ID	
	Center Marker			Center Marker	To turn the center marker ON/OFF
				Safety Zone	To set the safety zone (90%/80%/OFF)
	Screen Mode ^{a)}			Screen Mode	To select the Screen mode (4:3/16:9)
	Diag			Req	To request camera’s self-diagnostic data (available only when any abnormality has been detected during self-diagnosis)
				Reset	To erase the camera’s self-diagnostic data
				• Sel	To display the data read from the camera in order (No display when no abnormality has been detected during self-diagnosis)
	Bars			Bars Type	To select the type of color-bar signals: SMPTE (SPLIT)/SNG/FF 75%/FF 100%
File	Setup File			To store/retrieve a setup file	
	Copy to Slave			To copy the scene files to slave units	
RCP Config	RCP Adjusting	Buzzer Volume	• Call	To set the volume of the call buzzer	
			• Touch	To set the responding sound volume of the touch panel	
			• Switch	To set the confirmation sound volume of the self-illuminating switches	
			• Master	To set the total buzzer sound volume	
			Call Buzzer	To turn the call buzzer ON/OFF	
			Touch Click	To turn the responding sound of the touch panel ON/OFF	
			SW Click	To turn the confirmation sound of switches ON/OFF	
			All Off	To turn the volume of all the buzzers ON/OFF	

a) The item “Screen Mode” is displayed when Screen Md Enable is set to ON with Security of RCP Config on the OTHERS menu.

Menu Configuration and Basic Menu Operations

Menu	2ndary menu	Submenu	Control item	Function
RCP Config (cont.)	RCP Adjusting (cont.)	LED Bright	• Switch	To set the brightness of respective LEDs
			• Tally	
			• Other	
			• Master	To set the brightness of the all LEDs of the unit
	RE Setting		BLACK/FLARE	To select the function for the BLACK/FLARE knob Black: Black balance adjustment Flare: Flare balance adjustment
	VR Setting		VR STD Mode	To select the initial settings for IRIS or MASTER BLACK Adjustment mode: Absolute or Relative
			VR Rel. Scale IRIS VR	To select the response rate of the IRIS knob (relative-value adjustment rates: 1/1, 1/2, and 1/4, where 1/1 is the quickest response position)
			M. Black VR	(Only available for RCP-D50) To select the response rate of the MASTER BLACK knob (relative-value adjustment rates: 1/1, 1/2, and 1/4, where 1/1 is the quickest response position)
	Information			To display the software version of the unit
	Cable Comp		Cable Length	To set the length of the remote cable (5 m/25 m/50 m)
	SW Setting		• SW Assign/Sel	To allocate a function to the ASSIGN button No Assign: No assignment Black/Flare: Switching the function of the BLACK/FLARE knobs Black Auto: ON/OFF of the auto black ATW: ON/OFF of the auto tracing white balance TLCS: ON/OFF of the total level control function DynaLatitude: ON/OFF of the DynaLatitude function
	CAM No.		CAM ID->No.	To switch the display of the camera number/tally indication of the unit between camera ID and camera number
			• No.	To select the camera number to be displayed on the RCP
Date/Time Set	Date		• Year	Date adjustment of the clock built into the unit
			• Month	
		• Day		
		Set		
		Cancel		
	Time		• Hour	Time adjustment of the clock built into the unit
		• Minute		
		• Second		
		Set		
		Cancel		
Comm Link			Gain	To turn ON/OFF command link operation (activation of several cameras at the same time) of the gain
			Shutter	To turn ON/OFF command link operation of shutter settings
			R/B White	To turn ON/OFF command link operation of the white R/B adjustment
			R/B Black	To turn ON/OFF command link operation of the black R/B adjustment
			R/G/B Flare	To turn ON/OFF command link operation of the flare R/G/B adjustment
Comm Type			Protocol Type ^{a)}	To set the connection mode P Type 2: When connected to DXC-D35, DXC-D50, CCU-TX7, CCU-D50, DSR-300/370/390/500/570 P Type 7: When connected to CCU-TX50

a) Be sure to power off the camera system and then power it on again after changing the “Protocol Type” setting.

Menu	2ndary menu	Submenu	Control item	Function
RCP Config (cont.)	Security	Engineer Mode		To set whether to display “Status”, “Menu Set”, and “Code No.” or not (With Engineer Mode ON, all operative menu items are displayed regardless of the Advance Mode setting.)
		Status ^{a)}	Advance Mode	To switch between the Normal Setting mode and Advanced Setting mode of the menu
			Screen Md Enable	To set whether switching between 4:3 and 16:9 is enabled or not
			Pan/Tilt Enable	To set whether panning/tilting adjustment is enabled or not
			Power On Active	To specify the Panel Active and Iris/Master Black Active statuses when the unit is started up Full Active: To set the unit to the Panel Active status when started up IRIS/M.Black: To set the unit to the Iris/Master Black Active status when started up Lock: To set the unit to the Panel Lock status when started up Keep state: To set the unit to the previous state when started up
			Panel Active Lock	To set whether to use the Panel Active Lock function with a security code or not. Disable: Not to use the Panel Active Lock function Enable: To use the Panel Active Lock function by specifying a new security code Enable (Engineer Code): To use the Panel Active Lock function with the same security code as that for Engineer Mode
			Code Change	To change the security code for Panel Active Lock (displayed only when a security code for Panel Active Lock has been set)
		Menu Set ^{a)}		To select an item to be displayed on the function menu. Select the number (1-7) using • Cur, and select the item with • Sel: White, Black, Flare, Gamma/Knee, Detail, Cross Color, Skin Detail, Black STR, Black Gamma, Knee/DL, Gamma, Matrix, Skin Matrix, White Clip, TLCS, Auto Iris, CLS/EVS, Auto Knee, Low Key Sat, no jump
		Code No. ^{a)}	Code No.	To enable/disable the security code setting for Engineer Mode
			Code Change	To change the security code for Engineer Mode (displayed only when a security code for Engineer Mode has been set)
LCD	LCD Brightness/Contrast	• Bright	To set the brightness of the LCD of the unit	
		• Cont	To set the contrast of the LCD of the unit	
LCD Moni.	LCD Monitor Brightness/Contrast	• Bright	To set the brightness of the LCD of the unit when displaying the camera picture	
		• Cont	To set the contrast of the LCD of the unit when displaying the camera picture	
Memory Stick	Memory Stick	Format	To perform formatting of the Memory Stick	

a) The items “Status,” “Menu Set,” and “Code No.” are displayed only in Engineer Mode.

Menu Configuration and Basic Menu Operations

Menu Items with the DXC-637-Series Cameras

The “Control items” marked with ● are those assigned to the control knobs. The other items are operated on the menu display.

To operate the DXC-637-series cameras from this unit, it is necessary to connect the camera and this unit via the CCU-TX7.

The items displayed differ according to whether the unit is in Advanced Setting mode or in Normal Setting mode. The items shaded () in the table below are displayed only in Advanced Setting mode. Switching between Normal Setting mode and Advanced Setting mode is performed in RCP Config (Security → Status) on the OTHERS menu.

Paint menu (with the DXC-637 series)

Paint menu consists of pages 1 to 3.

Page	Menu	Control item	Function
Paint 1	White	White Preset	To retrieve the preset white balance settings in the camera
		Auto	To select the auto white balance adjustment mode ^{a)}
		Manual	To select the manual white balance adjustment mode ^{a)}
		ATW	To turn ON/OFF the Auto Tracing White function (which automatically adjusts the white balance when lighting conditions change)
		● R	To adjust the gain for the R signal in the white when Manual is pressed
		● B	To adjust the gain for the B signal in the white when Manual is pressed
	Black	Auto	To select the auto black balance adjustment mode ^{a)}
		Manual	To select the manual black balance adjustment mode ^{a)}
		● R	To adjust the gain of the R signal in the black
		● B	To adjust the gain of the B signal in the black
		● Master	To adjust the master black
	Gamma/Knee	Knee Preset	To turn ON/OFF the mode that uses the preset knee correction value
		Auto Knee	To turn the Auto Knee circuit ON/OFF
		● Knee Point	To adjust the level at which the knee correction starts. As the value becomes larger, the start level decreases, which enhances the knee correction effects.
	Paint 2	Detail	● Level
Paint 3	Knee/DL	Knee Preset	To turn ON/OFF the mode that uses the preset knee correction value
		Auto Knee	To turn the Auto Knee function ON/OFF
		● Point	To adjust the level at which the knee correction starts. As the value becomes larger, the start level decreases, which enhances the knee correction effects.
	Matrix	● Matrix	To select the Matrix Adjustment mode STD: Standard FL: For shooting under fluorescent light High Sat: High saturation (increasing the saturation of primary colors)

a) The Auto/Manual setting for Black is synchronized with that for White.

Function menu (with the DXC-637 series)

Menu	Control item	Function
Operation	Jump menu 1	To jump to the adjustment screen designated for Menu 1 in Menu Set ^{a)} (Default: White of Paint 1)
	Jump menu 2	To jump to the adjustment screen designated for Menu 2 in Menu Set ^{a)} (Default:Black of Paint 1)
	Jump menu 3	To jump to the adjustment screen designated for Menu 3 in Menu Set ^{a)} (Default: Flare of Paint 1)
	Jump menu 4	To jump to the adjustment screen designated for Menu 4 in Menu Set ^{a)} (Default: Gamma/Knee of Paint 1)
	Jump menu 5	To jump to the adjustment screen designated for Menu 5 in Menu Set ^{a)} (Default: Detail of Paint 2)
	Jump menu 6	To jump to the adjustment screen designated for Menu 6 in Menu Set ^{a)} (Default: Skin Detail of Paint 2)
	Jump menu 7	To jump to the adjustment screen designated for Menu 7 in Menu Set ^{a)} (Default: Matrix of Paint 3)
	Shutter	To turn the shutter function ON/OFF
	• Shutter	To select the shutter speed
	CLS	To turn the CLS (clear scan) function ON/OFF
	• CLS	To select the CLS frequency
• Master Gain	To select the master gain setting from among Hi/Mid/Low	
SW	ATW	To turn the ATW (auto tracing white balance) function (which automatically adjusts the white balance when lighting conditions change) ON/OFF
	Auto Knee	To turn the Auto Knee function ON/OFF
Lens/Pan ^{b)}	Option 1	To turn the option control function 1 ON/OFF
	Option 2	To turn the option control function 2 ON/OFF
	• Focus ^{c)}	To adjust the focus
	• Zoom ^{c)}	To adjust the zoom
	• Pan ^{d)}	To adjust panning of the tripod head
• Tilt ^{d)}	To adjust tilting of the tripod head	

a) The submenu “Menu Set” can be selected from Security of RCP Config on the OTHERS menu.

b) The item “Lens/Pan” is displayed when Pan/Tilt Enable is set to ON with Security of RCP Config on the OTHERS menu.

c) To control the lens from this unit, the optional focus zoom servo unit and the interface unit for the camera adapter and lens are required.

d) To control the tripod head from this unit, an electric tripod head and the interface unit for the camera adapter and tripod head are required.

Menu Configuration and Basic Menu Operations

OTHERS menu (with the DXC-637 series)

Menu	2ndary menu	Submenu	Control item	Function	
Camera Config	Title ID		Title IND	To turn the title display ON/OFF while the camera is in Color Bars mode	
			Clock IND	Switching of the clock indication Cam: To always display the clock indication Off: No clock indication	
File	Copy to Slave			To copy the status of the master unit to slave units	
RCP Config	RCP Adjusting	Buzzer Volume	• Call	To set the volume of the call buzzer	
			• Touch	To set the responding sound volume of the touch panel	
			• Switch	To set the confirmation sound volume of the self-illuminating switches	
			• Master	To set the total buzzer sound volume	
			Call Buzzer	To turn the call buzzer ON/OFF	
			Touch Click	To turn the responding sound of the touch panel ON/OFF	
			SW Click	To turn the confirmation sound of switches ON/OFF	
			All Off	To turn the volume of all the buzzers ON/OFF	
	LED Bright	• Switch	• Tally	To set the brightness of respective LEDs	
			• Other		
			• Master		To set the brightness of the all LEDs of the unit
	VR Setting		VR STD Mode	To select the initial settings for IRIS or MASTER BLACK Adjustment mode: Absolute or Relative	
			VR Rel. Scale IRIS VR	To select the response rate of the IRIS knob (relative-value adjustment rates: 1/1, 1/2, and 1/4, where 1/1 is the quickest response position)	
M. Black VR			(Only available for RCP-D50) To select the response rate of the MASTER BLACK knob (relative-value adjustment rates: 1/1, 1/2, and 1/4, where 1/1 is the quickest response position)		
Information			To display the software version of the unit		
Cable Comp		Cable Length	To set the length of the remote cable (5 m/25 m/50 m)		
SW Setting		• SW Assign/Sel	To allocate a function to the ASSIGN button No Assign: No assignment Black/Flare: Switching the function of the BLACK/FLARE knobs Black Auto: ON/OFF of the auto black (not operative) ATW: ON/OFF of the auto tracing white balance TLCS: ON/OFF of the total level control function (not operative) DynaLatitude: ON/OFF of the DynaLatitude function (not operative)		
CAM No.		• No.	To select the camera number to be displayed on the RCP		
Date/Time Set	Date	• Year	Date adjustment of the clock built into the unit		
		• Month			
		• Day			
		Set			
		Cancel			
	Time	• Hour	Time adjustment of the clock built into the unit		
		• Minute			
		• Second			
		Set			
		Cancel			

Menu	2ndary menu	Submenu	Control item	Function	
RCP Config (cont.)	Comm Link		Gain	To turn ON/OFF command link operation (activation of several cameras at the same time) of the gain	
			Shutter	To turn ON/OFF command link operation of shutter settings	
			R/B White	To turn ON/OFF command link operation of the white R/B adjustment	
			R/B Black	To turn ON/OFF command link operation of the black R/B adjustment	
			R/G/B Flare	To turn ON/OFF command link operation of the flare R/G/B adjustment	
	Comm Type		Protocol Type ^{a)}	To set the connection mode P Type 2: When connected to DXC-D35, DXC-D50, CCU-TX7, CCU-D50, DSR-300/370/390/500/570 P Type 7: When connected to CCU-TX50	
	Security	Engineer Mode			To set whether to display “Status”, “Menu Set”, and “Code No.” or not (With Engineer Mode ON, all operative menu items are displayed regardless of the Advance Mode setting.)
			Status ^{b)}	Advance Mode	To switch between the Normal Setting mode and Advanced Setting mode of the menu
				Screen Md Enable	To set whether switching between 4:3 and 16:9 is enabled or not
				Pan/Tilt Enable	To set whether panning/tilting adjustment is enabled or not
				Power On Active	To specify the Panel Active and Iris/Master Black Active statuses when the unit is started up Full Active: To set the unit to the Panel Active status when started up IRIS/M.Black: To set the unit to the Iris/Master Black Active status when started up Lock: To set the unit to the Panel Lock status when started up Keep state: To set the unit to the previous state when started up
				Panel Active Lock	To set whether to use the Panel Active Lock function with a security code or not. Disable: Not to use the Panel Active Lock function Enable: To use the Panel Active Lock function by specifying a new security code Enable (Engineer Code): To use the Panel Active Lock function with the same security code as that for Engineer Mode
			Code Change	To change the security code for Panel Active Lock (displayed only when a security code for Panel Active Lock has been set)	
Menu Set ^{b)}				To select an item to be displayed on the function menu. Select the number (1-7) using • Cur, and select the item with • Sel: White, Black, Flare, Gamma/Knee, Detail, Cross Color, Skin Detail, Black STR, Black Gamma, Knee/DL, Gamma, Matrix, Skin Matrix, White Clip, TLCS, Auto Iris, CLS/EVS, Auto Knee, Low Key Sat, no jump	
			Code No. ^{b)}	Code No.	To enable/disable the security code setting for Engineer Mode
Code Change	To change the security code for Engineer Mode (displayed only when a security code for Engineer Mode has been set)				
LCD	LCD Brightness/Contrast	• Bright	To set the brightness of the LCD of the unit		
		• Cont	To set the contrast of the LCD of the unit		
LCD Moni.	LCD Monitor Brightness/Contrast	• Bright	To set the brightness of the LCD of the unit when displaying the camera picture		
		• Cont	To set the contrast of the LCD of the unit when displaying the camera picture		
Memory Stick	Memory Stick	Format	To perform formatting of the Memory Stick		

a) Be sure to power off the camera system and then power it on again after changing the “Protocol Type” setting.

b) The items “Status,” “Menu Set,” and “Code No.” are displayed only in Engineer Mode.

Menu Configuration and Basic Menu Operations

Menu Items with the CCU-TX50

The “Control items” marked with ● are those assigned to the control knobs. The other items are operated on the menu display.

The items displayed differ according to whether the unit is in Advanced Setting mode or in Normal Setting mode. The items shaded () in the table below are displayed only in Advanced Setting mode. Switching between Normal Setting mode and Advanced Setting mode is performed in RCP Config (Security → Status) on the OTHERS menu.

Paint menu (with the CCU-TX50)

Paint menu consists of pages 1 to 5. You can select page 1 through 3 directly by pressing the MENU buttons, PAINT 1, PAINT 2, or PAINT 3. Pressing ▲ or ▼ of the page selected with a MENU button flip pages 1 through 5 in sequence.

Paint 4 and 5 can also be selected in sequence by pressing the PAINT 3 button.

Page	Menu	Submenu	Control item	Function
Paint 1	White		White Preset	To retrieve the white balance settings preset by the camera
			Memory A	To retrieve the white-balance settings stored in Memory A. The retrieved settings can be adjusted in Auto or Manual mode (the adjusted values are stored in Memory A).
			Memory B	To retrieve the white-balance settings stored in Memory B. The retrieved settings can be adjusted in Auto or Manual mode (the adjusted values are stored in Memory B).
			ATW	To turn ON/OFF the Auto Tracing White function (which automatically adjusts the white balance when lighting conditions change)
			● R	To adjust the gain of the R signal in the white when Memory A or Memory B is pressed
			● B	To adjust the gain of the B signal in the white when Memory A or Memory B is pressed
	Black		● R	To adjust the gain of the R signal in the black
			● B	To adjust the gain of the B signal in the black
			● Master	To adjust the master black
	Flare		Flare Off	To turn the flare (black level when flare is generated) correction function ON/OFF
			● R	To adjust the amount of flare correction for the R signal
			● G	To adjust the amount of flare correction for the G signal
	Gamma/Knee		● B	To adjust the amount of flare correction for the B signal
			Auto Knee	To turn the Auto Knee circuit ON/OFF
			● Gamma	To adjust the gamma level
			● Blk Gamma	To adjust the black gamma level
			● Knee Point	To adjust the level at which the knee correction starts. As the value becomes larger, the start level decreases, which enhances the knee correction effects.
		● Knee Slope	To adjust the knee slope (amount of knee correction)	

Page	Menu	Submenu	Control item	Function
Paint 2	Detail	Detail 1	• Level	To adjust the detail (contour correction) level
			• H/V Ratio	To adjust the ratio of V (Vertical) detail to H (Horizontal) detail in detail correction. As the value becomes larger, the V detail ratio increases.
			• Frequency	To adjust the boost frequency (thickness of contour lines) for the detail correction
		Detail 2	• Crispening	To adjust the crispening level (appropriate level at which details of noise signals are removed)
			• Level Dep	To adjust the level dependence (level at which the detail signal starts being suppressed)
	Cross Color		• CCS Level	To adjust the cross color suppress level to suppress the phenomenon of color jittering or coloring when a minutely striped pattern is shot
	Skin Detail		Detail Gate	To turn ON/OFF the skin gate area (target color range of skin detail correction or skin matrix adjustment)
			Skin DTL	To turn the skin detail function (which suppresses the contour correction in the selected area) ON/OFF
			Auto Skin	The unit will go to Standby mode when this button is pressed, and will automatically start obtaining the skin gate area data when Start is pressed.
			• Level	To adjust the amount of skin detail correction. As the value becomes larger, the amount of detail in the skin gate area decreases.
			• Phase	To adjust the color phase of the designated area
			• Width	To adjust the color width of the designated area
			• Sat	To adjust the color saturation of the designated area
	Black Gamma		• R	To adjust the level of the black R gamma
• B			To adjust the level of the black B gamma	
• Master			To adjust the master black gamma	
Paint 3	Knee/DL		Auto Knee	To turn the auto knee ON/OFF
			• Point	To adjust the level at which the knee correction starts. As the value becomes larger, the start level decreases, which enhances the knee correction effects.
			• Slope	To adjust the knee slope (amount of knee correction)
			Gamma	
	• B	To adjust the level of the B gamma		
	• Master	To adjust the master gamma		
	Matrix	Matrix 1	• Hue	To adjust the hue of the linear matrix
			• Sat	To adjust the color saturation of the linear matrix
			• Matrix	To select the Matrix Adjustment mode STD: Standard FL: For shooting under fluorescent light High Sat: High saturation (increasing the saturation of primary colors)
		Matrix 2	• R-G/• G-B/• B-R	To adjust the color tone for the R-G, G-B, or B-R elements of the matrix
			• Matrix	To select the Matrix Adjustment mode
		Matrix 3	• R-B/• G-R/• B-G	To adjust the color tone for the R-B, G-R, or B-G elements of the matrix
			• Matrix	To select the Matrix Adjustment mode
	Skin Matrix		Skin Matrix	To select the skin matrix function ON/OFF
			• Hue	To adjust the hue of the designated area
			• Sat	To adjust the color saturation of the designated area

Menu Configuration and Basic Menu Operations

Page	Menu	Submenu	Control item	Function
Paint 4	White Clip		• Master	To adjust the amount of white clip (the highest white level). As the value becomes larger, the output level decreases.
			TLCS	To turn the TLCS (total level control) function ON/OFF
	TLCS		• AGC/C.Point	To set the f-stop value (f-2, f-2.8, f-4, or f-5.6) at which the iris control is switched to AGC (auto gain control)
			• AGC/Limit	To set the upper limit value for the AGC (3 dB/6 dB/9 dB/12 dB/18 dB) adjustment
			• AE/C.Point	To set the f-stop value (f-5.6, f-8, f-11, or f-16) at which the iris control is switched to the AE (auto exposure)
			• AE/Limit	To set the upper limit value for AE control (100/150/200/250)
	Auto Iris		STD	To select the standard auto iris mode
			Spot Light	To select the auto iris mode for shooting spot-lit subjects
			Back Light	To select the auto iris mode for shooting back-lit subjects
	CLS/EVS		TLCS	To turn the TLCS (total level control) function ON/OFF
			Shutter	To turn the shutter function ON/OFF
			CLS	To turn the CLS (clear scan) function (which reduces noise on the horizontal scan lines when the monitor screen connected to a PC is shot) ON/OFF
			EVS	To turn the EVS mode (which reduces flicker by increasing the vertical resolutions) ON/OFF
			• Shutter	To select the shutter speed
			• CLS	To adjust the CLS frequency
Paint 5	Low Key Sat		• Level	To adjust the low key saturation level
	Auto Knee		Adaptive	To turn ON/OFF the function that makes the knee correction slope smooth to make the gradation natural

Function menu (with the CCU-TX50)

Menu	Control item	Function
Operation	Jump menu 1	To jump to the adjustment screen designated for Menu 1 in Menu Set ^{a)} (Default: White of Paint 1)
	Jump menu 2	To jump to the adjustment screen designated for Menu 2 in Menu Set ^{a)} (Default:Black of Paint 1)
	Jump menu 3	To jump to the adjustment screen designated for Menu 3 in Menu Set ^{a)} (Default: Flare of Paint 1)
	Jump menu 4	To jump to the adjustment screen designated for Menu 4 in Menu Set ^{a)} (Default: Gamma/Knee of Paint 1)
	Jump menu 5	To jump to the adjustment screen designated for Menu 5 in Menu Set ^{a)} (Default: Detail of Paint 2)
	Jump menu 6	To jump to the adjustment screen designated for Menu 6 in Menu Set ^{a)} (Default: Skin Detail of Paint 2)
	Jump menu 7	To jump to the adjustment screen designated for Menu 7 in Menu Set ^{a)} (Default: Matrix of Paint 3)
	Shutter	To turn the shutter function ON/OFF
	• Shutter	To select the shutter speed
	CLS	To turn the CLS (clear scan) function ON/OFF
	• CLS	To select the CLS frequency
	TLCS	To turn the TLCS (total level control) function ON/OFF
	• Master Gain	To select the master gain value among -3/0/3/6/9/12/18/24/30/36 dB
SW	5600K	To turn the color temperature 5600K ON/OFF
	Skin Detail	To turn the skin detail function ON/OFF
	Detail Gate	To turn ON/OFF the display for the skin detail gate area (target color range for the skin detail correction or the skin matrix adjustment)
	ATW	To turn the ATW (auto tracing white balance) function (which automatically adjusts the white balance when lighting conditions change) ON/OFF
	TLCS	To turn the TLCS (total level control) function ON/OFF
	Auto Knee	To turn the Auto Knee function ON/OFF
	Skin Matrix	To turn the skin matrix function ON/OFF
	Flare Off	To turn the flare correction function ON/OFF (OFF while the button is lit)
Lens/Pan ^{b)}	Option 1	To turn the option control function 1 ON/OFF
	Option 2	To turn the option control function 2 ON/OFF
	• Focus ^{c)}	To adjust the focus
	• Zoom ^{c)}	To adjust the zoom
	• Pan ^{d)}	To adjust panning of the tripod head
	• Tilt ^{d)}	To adjust tilting of the tripod head

a) The submenu “Menu Set” can be selected from Security of RCP Config on the OTHERS menu.

b) The item “Lens/Pan” is displayed when Pan/Tilt Enable is set to ON with Security of RCP Config on the OTHERS menu.

c) To control the lens from this unit, the optional focus zoom servo unit and the interface unit for the camera adapter and lens are required.

In addition, special settings must be made on the connected CA-TX50. For details, consult your Sony dealer.

d) To control the tripod head from this unit, an electric tripod head and the interface unit for the camera adapter and tripod head are required.

In addition, special settings must be made on the connected CA-TX50. For details, consult your Sony dealer.

Menu Configuration and Basic Menu Operations

OTHERS menu (with the CCU-TX50)

Menu	2ndary menu	Submenu	Control item	Function
Adjusting	White Shading		• R	To adjust the V white shading (vertical variation of the white) of the R signal
			• G	To adjust the V white shading of the G signal
			• B	To adjust the V white shading of the B signal
Camera Config	Screen Mode ^{a)}		Screen Mode	To select the Screen mode (4:3/16:9)
File	Scene Trans		CAM->MS	To transfer a scene file (from the camera to the Memory Stick)
			MS->CAM	To transfer a scene file (from the Memory Stick to the camera)
RCP Config	RCP Adjusting	Buzzer Volume	• Call	To set the volume of the call buzzer
			• Touch	To set the responding sound volume of the touch panel
			• Switch	To set the confirmation sound volume of the self-illuminating switches
			• Master	To set the total buzzer sound volume
			Call Buzzer	To turn the call buzzer ON/OFF
			Touch Click	To turn the responding sound of the touch panel ON/OFF
			SW Click	To turn the confirmation sound of switches ON/OFF
			All Off	To turn the volume of all the buzzers ON/OFF
	LED Bright	• Switch	To set the brightness of respective LEDs	
		• Tally		
		• Other		
		• Master	To set the brightness of the all LEDs of the unit	
	RE Setting		BLACK/FLARE	To select the function for the BLACK/FLARE knob Black: Black balance adjustment Flare: Flare balance adjustment
	VR Setting		VR STD Mode	To select the initial settings for IRIS or MASTER BLACK adjustment mode: Absolute or Relative
			VR Rel. Scale IRIS VR	To select the response rate of the IRIS knob (relative-value adjustment rates: 1/1, 1/2, and 1/4, where 1/1 is the quickest response position)
		M. Black VR	(Only available for RCP-D50) To select the response rate of the MASTER BLACK knob (relative-value adjustment rates: 1/1, 1/2, and 1/4, where 1/1 is the quickest response position)	
Information			To display the software version of the unit	
Cable Comp		Cable Length	To set the length of the remote cable (5 m/25 m/50 m)	
SW Setting		• SW Assign/Sel	To allocate a function to the ASSIGN button No Assign: No assignment Black/Flare: Switching the function of the BLACK/FLARE knobs Black Auto: ON/OFF of the auto black (Not operative) ATW: ON/OFF of the auto tracing white balance TLCS: ON/OFF of the total level control function DynaLatitude: ON/OFF of the DynaLatitude function (Not operative) CCU character: Switching the CCU-TX50 character pages	
CAM No.		CAM ID->No.	To switch the display of the camera number/tally indication of the unit between camera ID and camera number ^{b)}	
		• No.	To select the camera number to be displayed on the RCP	

a) The item "Screen Mode" is displayed when Screen Md Enable is set to ON with Security of RCP Config on the OTHERS menu.

b) Camera ID cannot be displayed when connected to the CCU-TX50.

Menu	2ndary menu	Submenu	Control item	Function
RCP Config (cont.)	Date/Time Set	Date	• Year	Date adjustment of the clock built into the unit
			• Month	
			• Day	
			Set	
			Cancel	
		Time	• Hour	Time adjustment of the clock built into the unit
			• Minute	
			• Second	
			Set	
			Cancel	
Comm Type		Protocol Type ^{a)}	To set the connection mode P Type 2: When connected to DXC-D35, DXC-D50, CCU-TX7, CCU-D50, DSR-300/370/390/500/570 P Type 7: When connected to CCU-TX50	
Security	Engineer Mode		To set whether to display “Status”, “Menu Set”, and “Code No.” or not (With Engineer Mode ON, all operative menu items are displayed regardless of the Advance Mode setting.)	
	Status ^{b)}	Advance Mode	To switch between the Normal Setting mode and Advanced Setting mode of the menu	
		Screen Md Enable	To set whether switching between 4:3 and 16:9 is enabled or not	
		Pan/Tilt Enable	To set whether panning/tilting adjustment is enabled or not	
		Power On Active	To specify the Panel Active and Iris/Master Black Active statuses when the unit is started up Full Active: To set the unit to the Panel Active status when started up IRIS/M.Black: To set the unit to the Iris/Master Black Active status when started up Lock: To set the unit to the Panel Lock status when started up Keep state: To set the unit to the previous state when started up	
		Panel Active Lock	To set whether to use the Panel Active Lock function with a security code or not. Disable: Not to use the Panel Active Lock function Enable: To use the Panel Active Lock function by specifying a new security code Enable (Engineer Code): To use the Panel Active Lock function with the same security code as that for Engineer Mode	
		Code Change	To change the security code for Panel Active Lock (displayed only when a security code for Panel Active Lock has been set)	
	Menu Set ^{b)}		To select an item to be displayed on the function menu. Select the number (1-7) using • Cur, and select the item with • Sel: White, Black, Flare, Gamma/Knee, Detail, Cross Color, Skin Detail, Black STR, Black Gamma, Knee/DL, Gamma, Matrix, Skin Matrix, White Clip, TLCS, Auto Iris, CLS/EVS, Auto Knee, Low Key Sat, no jump	
	Code No. ^{b)}	Code No.	To enable/disable the security code setting for Engineer Mode	
Code Change		To change the security code for Engineer Mode (displayed only when a security code for Engineer Mode has been set)		

a) Be sure to power off the camera system and then power it on again after changing the “Protocol Type” setting.

b) The items “Status,” “Menu Set,” and “Code No.” are displayed only in Engineer Mode.

Menu Configuration and Basic Menu Operations

Menu	2ndary menu	Submenu	Control item	Function
LCD (cont.)	LCD Brightness/Contrast		• Bright	To set the brightness of the LCD of the unit
			• Cont	To set the contrast of the LCD of the unit
LCD Moni.	LCD Monitor Brightness/Contrast		• Bright	To set the brightness of the LCD of the unit when displaying the camera picture
			• Cont	To set the contrast of the LCD of the unit when displaying the camera picture
Memory Stick	Memory Stick		Format	To perform formatting of the Memory Stick

Initial Settings

Setting the Operating Conditions of the RCP-D50/D51

By using the RCP Config menu or LCD setting display, you can set the built-in clock of the RCP-D50/D51 and adjust various conditions of the RCP-D50/D51, such as the sound volume of the warning buzzer and the brightness of the indicators and LCD.

Displaying the RCP Config menu/LCD setting display

Proceed as follows:

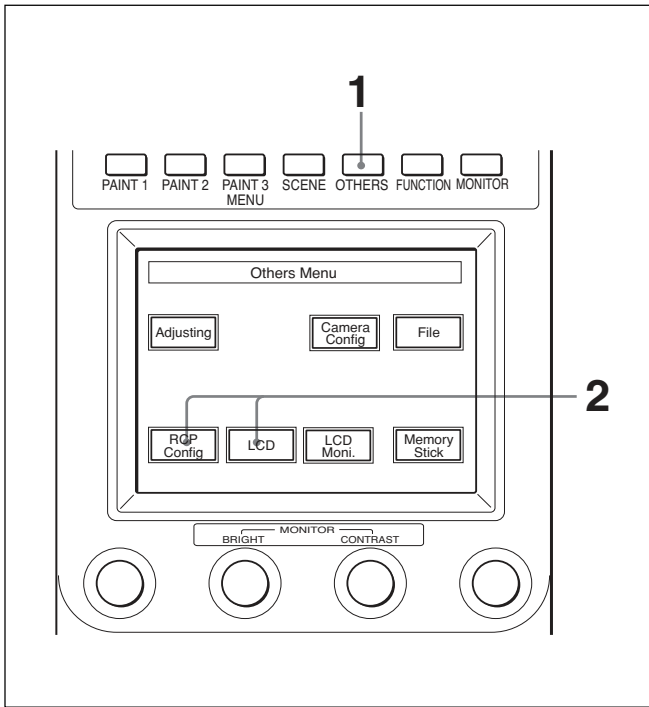

- 1 Press to light the OTHERS button of the menu operation block.

The OTHERS menu appears.

- 2 To display RCP Config menu, press **[RCP Config]**.

The RCP Config menu appears.

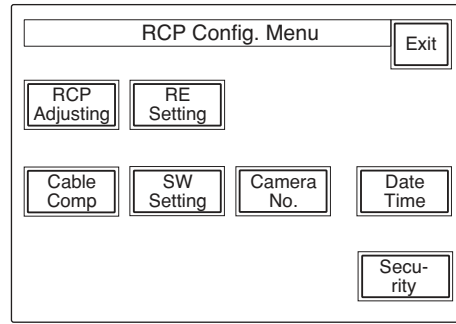

To obtain the LCD setting display, press **[LCD]**.

The LCD setting display (*page 48*) appears.

Setting the Built-in Clock

The RCP-D50/D51 has a built-in clock to record the date and time when scene files are saved to **Memory Sticks**.

To set the clock, proceed as follows:

- 1 Press the OTHERS button in the Menu operation block so that the OTHERS menu is displayed on the LCD, then press **[RCP Config]** to call the RCP Config menu.

- 2 Set the menu to Advanced Setting mode.

- 1) Press **[Security]** on the RCP Config menu.

- 2) Press and highlight **[Engineer Mode]**.

The **[Status]**, **[Menu Set]**, and **[Code No.]** buttons are displayed.

- 3) Press **[Status]**.

The Security Status menu appears.

- 4) Press **[Advance Mode]**.

- 3 Press **[Date/Time]** on the RCP Config menu.

The current setting is displayed on the Date/Time Set menu.

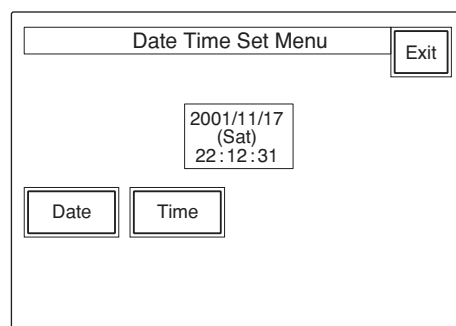

Initial Settings

4 To set the date:

1) Press and light **Date**.

The screenshot shows the 'Date Time Setting' menu. At the top right is an 'Exit' button. The current date and time are displayed as '2001/11/17 (Sat) 22:12:31'. Below this, there are four buttons: 'Date', 'Time', 'Set', and 'Cancel'. The 'Date' button is highlighted. Underneath these buttons are three input fields for 'Year', 'Month', and 'Day', containing the values '2001', '8', and '8' respectively.

2) Set the Year, Month and Day with the left three control knobs.

3) Press **Set**.

The set date becomes valid.

To restore the previous setting, press **Cancel** instead of **Set**.

5 To set the time:

1) Press and light **Time**.

The screenshot shows the 'Date Time Setting' menu. The 'Time' button is highlighted. The input fields for 'Hour', 'Minute', and 'Second' now contain the values '17', '32', and '25' respectively. The 'Date' and 'Set' buttons are no longer highlighted.

2) Set the Hour, Minute and Second with the left three control knobs.

3) Press **Set** in synchronization with a time signal.

The set time becomes valid.

To resume the previous setting, press **Cancel** instead of **Set**.

When the clock setting is completed

Press **Exit** to leave the menu.

Adjusting the Buzzer Sound

A buzzer sounds on the RCP-D50/D51 when it receives call signal or a panel control is operated. When required, you may turn on/off the buzzer or adjust the sound volume.

To adjust the buzzer, proceed as follows:

1 Press **RCP Adjusting** on the RCP Config menu.

The RCP adjustment menu appears.

The screenshot shows the RCP adjustment menu. It features an 'Exit' button at the top right. Below it are two buttons: 'Clear' and 'Buzzer Volume'. The 'Buzzer Volume' button is highlighted.

2 Press and light **Buzzer Volume**.

The lower half of the display becomes the Buzzer Volume adjustment display.

The screenshot shows the Buzzer Volume adjustment display. It features an 'Exit' button at the top right. Below it are two buttons: 'Clear' and 'Buzzer Volume'. The 'Buzzer Volume' button is highlighted. Below these buttons is a large 'Buzzer Volume' label. Underneath this label are four buttons: 'Call Buzzer', 'Touch Click', 'SW Click', and 'All Off'. Below these buttons are four input fields, each containing the value '50'. Below the input fields are four labels: 'Call', 'Touch', 'Switch', and 'Master'.

3 Adjust the levels with the corresponding control knobs (50 is the standard value with all items).

Call: Sound volume of the buzzer when a call signal is received

Touch: Sound volume of the buzzer when a button displayed on the menu display is operated

Switch: Sound volume of the buzzer when a button on the panel is operated

The master volume can be adjusted with the rightmost control knob (**Master**).

To turn on/off the buzzers independently

Press the corresponding button. When it is lit, the buzzer is on.

Call Buzzer: For the buzzer sound when a call signal is received

Touch Click: For the buzzer sound when a button displayed on the menu display is operated

SW Click: For the buzzer sound when a button on the panel is operated

To turn off all the buzzers

Press and light **All Off**.

When the adjustment is completed

Press **Exit** to leave the menu.

Adjusting the Brightness of the LEDs

You can adjust the brightness of the LEDs of the panel buttons and camera number/tally indication window. To adjust the brightness, proceed as follows.

- 1 Press **RCP Adjusting** on the RCP Config menu to display the RCP adjustment menu.
- 2 Press and light **LED Bright**.

The lower half of the display becomes the LED Brightness adjustment display.

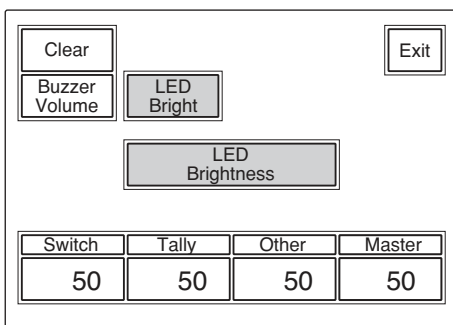

- 3 Adjust the brightness with the corresponding control knobs (50 is the standard value with all items).

Switch: Brightness of the built-in LEDs of the control buttons

Tally: Brightness of the built-in LEDs of the camera number/tally indication window

Other: Brightness of the other LED indicators/

lamps, including the master black indicator and f-number indicator

The master brightness can be adjusted with the rightmost control knob (**Master**).

When the adjustment is completed

Press **Exit** to leave the menu.

Changing the Functions of the Rotary Encoders

You can change the functions of BLACK/FLARE control knobs.

Proceed as follows:

- 1 Press **RE Setting** on the RCP Config menu to obtain the Rotary Encoder Setting display.

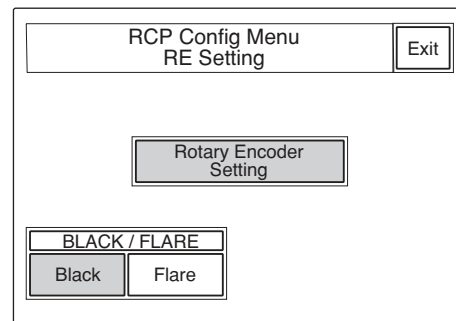

- 2 When changing the function of the BLACK/FLARE control knobs, press **Black** or **Flare** as desired.

When the adjustment is completed

Press **Exit** to leave the menu.

Initial Settings

Adjusting the Brightness/ Contrast of the LCD

You can adjust the brightness and contrast of the display of the menu control block.
Proceed as follows:

- 1 Press **[LCD]** on the OTHERS menu to display the LCD setting display.

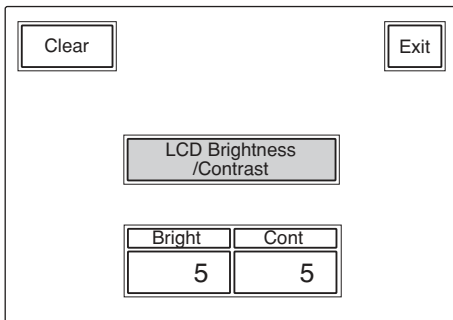

- 2 Adjust **Bright** and **Cont** (5 is the standard value with both items).

To adjust the brightness and contrast for camera pictures

- 1 Press **[LCD Moni.]** on the OTHERS menu to display the LCD setting display.
- 2 Adjust **Bright** and **Cont** (5 is the standard value with both items).

When the adjustment is completed

Press **[Exit]** to leave the menu.

Assigning a Function to the ASSIGN Button

You can assign a function to the ASSIGN button.
Note that the assignable functions depend on the connected camera.
Proceed as follows:

- 1 Press the OTHERS button in the Menu operation block so that the OTHERS menu is displayed on the LCD, then press **[RCP Config]** to call the RCP Config menu.

- 2 Set the menu to Advanced Setting mode.

1) Press **[Security]** on the RCP Config menu.

2) Press and highlight **[Engineer Mode]**.

The **[Status]**, **[Menu Set]**, and **[Code No.]** buttons are displayed.

3) Press **[Status]**.

The Security Status menu appears.

4) Press **[Advance Mode]**.

- 3 Press **[SW Setting]** on the RCP Config menu to obtain the SW Setting display.

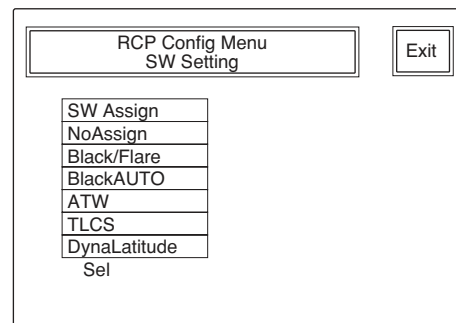

- 4 Turn the second left control knob (**Sel**) to highlight the function to be assigned.

NoAssign (default): No assignment

Black/Flare: Switching the function of the BLACK/FLARE knobs

Black AUTO: ON/OFF of the auto black

ATW: ON/OFF of the auto tracing white balance

TLCS: ON/OFF of the total level control function

DynaLatitude: ON/OFF of the DynaLatitude function

Note

Some functions may be unoperative, depending on the connected camera.

When the assignment is completed

Press **[Exit]** to leave the menu.

Specifying the Security Codes

You can authorize specific persons to set the menu to Engineer mode, to operate this panel, and to adjust the iris and master black by specifying a security code.

Locking Engineer mode with a security code

- 1 Press the OTHERS button in the Menu operation block so that the OTHERS menu is displayed on the LCD, then press **[RCP Config]** to call the RCP Config menu.
- 2 Set the menu to Engineer mode.
 - 1) Press **[Security]** on the RCP Config menu.
 - 2) Press and highlight **[Engineer Mode]**.
The **[Status]**, **[Menu Set]**, and **[Code No.]** buttons are displayed.
- 3 Press **[Code No.]**.
The Security Code setting display appears.
- 4 Press **[Enable]**.
The Security Code input display now appears and “Input New Code No.” is displayed.
- 5 Enter a security code and press **[Enter]**.
Use **[0]** to **[9]** to enter the security code (up to 8 digits).
Asterisks, each representing one digit of the entered security code, are displayed in the upper New Code No. box.
Press **[Back Space]** to cancel previous input one at a time.
When you press **[Enter]**, the message “Input Again to Confirm” is displayed.
- 6 Enter the security code again and press **[Enter]**.

Asterisks, each representing one digit of the entered security code, are displayed in the lower New Code No. box.

If you enter an incorrect security code, the message “!!!Code No. NG!!!” is displayed.

When you enter the correct security code, the Security Code setting display is resumed with highlighted **[Enable]** and additional **[Code Change]**.

After this setting, the Security Code input display appears when you press **[Engineer Mode]** of the Security menu.

Releasing the security code lock of Engineer mode

- 1 When a security code for Engineer mode has been set, operate in the same manner as step 1 through step 4 in “Locking Engineer mode with a security code.”
The Security Code input display appears.
- 2 Enter the security code and press **[Enter]**.
The security code lock is released.

Locking panel operations, iris/master black adjustments menu with a security code (Panel Active Lock)

- 1 Press the OTHERS button in the Menu operation block so that the OTHERS menu is displayed on the LCD, then press **[RCP Config]** to call the RCP Config menu.
- 2 Set the menu to Engineer mode.
 - 1) Press **[Security]** on the RCP Config menu.
 - 2) Press and highlight **[Engineer Mode]**.
The **[Status]**, **[Menu Set]**, and **[Code No.]** buttons are displayed.
- 3 Press **[Status]**.
The Security Status menu appears.
- 4 Press **▶** to display the second page and press **[Enable]**.

Initial Settings

The Security Code input display appears. (Pressing **Enable (ENG Code)** registers the same security code as Engineer mode for Panel Active Lock.)

- 5** Operate in the same manner as step **5** and step **6** in “Locking Engineer mode with a security code.”

The Security Status menu is resumed with highlighted **Enable** and additional **Code Change**.

After this setting, when you hold the PANEL ACTIVE button pressed for more than 2 seconds, the message “!!Panel Locked!!” is displayed and the panel is locked.

When the panel is locked, the Security Code input display appears when you press the PANEL ACTIVE or IRIS/M. BLACK ACTIVE button.

If the correct security code is not entered, the lock is not released.

Notes

- If no security code has been set for Engineer mode, **Enable (ENG Code)** is not displayed.
- When the panel is locked with a security code, the panel lock is not released even when power to this unit is shut off.
The panel lock is released when you select Engineer mode.
- When the panel is locked with a security code, only Security from RCP Config can be selected in the OTHERS menu.
- If you specify a security code only for Panel Active Lock without setting a security code for Engineer mode, Engineer mode is also locked with the security code for Panel Active Lock when the panel is locked.

Disabling the security code for Panel Active Lock

- 1** When Panel Active Lock has been enabled, operate in the same manner as step **1** through step **3** in “Locking panel operations, iris/master black adjustments menu with a security code (Panel Active Lock).”

The Security Code input display appears.

- 2** Press **▶** to display the second page and press **Disable**.

The security code is disabled.

Changing a security code

- 1** Press **Code Change** on the Security Code setting display.

The Security Code input display appears and the message “Input Old Code No.” is displayed.

- 2** Enter the current security code and press **Enter**.

Asterisks, each representing one digit of the entered security code, are displayed in the Old Code No. box.

When you press **Enter**, the message “Input New Code No.” is displayed.

- 3** Enter a new security code and press **Enter**.

The message “Input Again to Confirm” is displayed.

- 4** Enter the new security code again and press **Enter**.

The new security code becomes valid.

Note

If no security code has been set, **Code Change** is not displayed.

If you forget the specified security code(s)

- 1** Shut down power to the unit, then reapply power while holding the MASTER and CLOSE buttons pressed.

The confirmation display for canceling the securing code appears.

- 2** Press **OK**.

The message “Code No. cleared” is displayed, and the security code settings are canceled.

File Operations

This unit can operate two types of files: scene files and setup files.

Setting data of cameras can be registered as scene files or setup files and recalled as required.

The table below shows the setting items which can be registered as either of the files.

Setting item	Setup file	Scene file		
	DXC-D30/D35 series only	DXC-D30/D35 series	DXC-D50 series	DXC-637 series
Selecting shooting picture or color bars		yes		yes
Master black	yes	yes	yes	yes
Iris		yes		yes
Auto iris mode		yes	yes	yes
Master gain		yes	yes	yes
TLCS		yes		
Upper limit value for AGC		yes		
Initial F-stop value for AGC		yes		
Initial F-stop value for AE		yes		
Shutter/Clear scan		yes	yes	yes
Shutter speed		yes	yes	yes
Clear scan frequency		yes	yes	yes
Filter position		yes	yes	
Selecting white balance or black balance adjustment		yes		yes
ATW ON/OFF		yes	yes	yes
R/B white balance adjustment		yes	yes	yes
R/B black balance adjustment		yes	yes	yes
Flare correction ON/OFF		yes	yes	
R/G/B flare correction		yes	yes	
Detail correction ON/OFF		yes		
Detail level	yes	yes	yes	yes
Detail boost frequency	yes	yes	yes	
Crispening level	yes	yes	yes	
Level dependence value	yes	yes	yes	
Detail H/V	yes	yes	yes	
V-detail limit value	yes	yes		
Highlight detail	yes	yes		
After gamma detail	yes	yes		
Aperture correction ON/OFF		yes		
Aperture correction value	yes	yes		
Knee aperture correction ON/OFF		yes		
Knee aperture correction value	yes	yes		
Cross color suppress value	yes	yes	yes	
R/G comb filter ON/OFF	yes	yes		
Knee correction mode		yes		yes
Master knee point	yes	yes	yes	yes
Master knee slope	yes	yes	yes	
White clip circuit ON/OFF		yes		
White clip value		yes	yes	

File Operations

Setting item	Setup file	Scene file		
	DXC-D30/D35 series only	DXC-D30/D35 series	DXC-D50 series	DXC-637 series
Gamma correction on/off		yes		
Master gamma	yes	yes	yes	
R/B gamma		yes	yes	
Master black gamma			yes	
R/B black gamma			yes	
Gamma initial gain	yes	yes		
Black stretch level	yes	yes		
Upper/lower limit value for black stretch	yes	yes		
Upper/lower limit value for black compress	yes	yes		
DynaLatitude effect		yes		
Matrix adjustment ON/OFF		yes		
Saturation/hue	yes	yes	yes	
Matrix adjustment mode			yes	yes
Matrix parameter (R-G, R-B, G-R, G-B, B-R, B-G)	yes	yes	yes	
Skin detail level		yes	yes	
Skin matrix saturation/hue	yes	yes	yes	
Skin gate position/size		yes		
Position/size of skin gate detect window		yes		
EVS			yes	
Low Key saturation			yes	
Focus/zoom		yes		yes
Pan/tilt		yes		yes
ON/OFFselection of optional control 1 or 2		yes		yes

Operating Scene Files

Scene files are stored in the memory of this unit (or of the camera when using the DXC-D50-series camera). Among the setting items listed in the table on pages 51 and 52, the settings for those items that have “yes” in the scene-file column can be stored as a scene file. Up to 20 scene files can be registered and retrieved as required. To register or retrieve scene files, use the Scene File Operation menu.

Registering a scene file

Use the Scene File Operation menu for storing a scene file, in the following manner:

- 1 Make the adjustment for the setting items that have “yes” in the scene-file column in the table on pages 51 and 52, until the values you wish to store are obtained.
- 2 Press the SCENE button in the menu operation block to display the Scene File operation menu on the LCD.

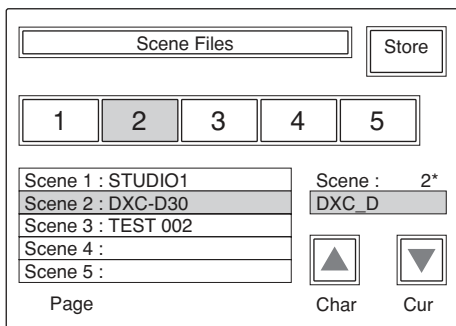

- 3 Press **[Store]**.
- 4 Enter a filename (up to eight characters) in the filename input box.

Moving the cursor: Turn the rightmost knob (**Cur**) until the cursor comes to the position where you wish to enter a character.

Selecting a character: Turn the second knob (**Char**) from the left until the character which you wish to enter appears.

- 5 Press a scene file select button (1 to 20) corresponding to the memory cell in which you wish to store the setting data.

If the scene file button corresponding to the memory cell in which you wish to store data is not displayed, press either the ▲ or ▼ button at the lower-right position. You can change the scene file buttons by 5, in the order of **[1]** to **[5]**, **[6]** to **[10]**, **[11]** to **[15]**, and **[16]** to **[20]**. You can also change the buttons one by one. When the knob at the leftmost position (**Page**) is turned clockwise, larger-numbered buttons are displayed one by one. When the knob is turned counterclockwise, smaller-numbered buttons are displayed in turn.

The selected file number is displayed above the filename input box.

Retrieving a scene file

Use the Scene File operation menu for retrieving a scene file.

- 1 Press the SCENE button in the menu operation block to display the Scene File Operation menu on the LCD.
- 2 Press either the ▲ or ▼ button, or turn the knob at the leftmost position (**Page**) until the file button corresponding to the desired file is displayed.
- 3 Press the button corresponding to the scene file to be retrieved.

The selected scene file is retrieved, and the settings of the camera are replaced with the data of the retrieved file.

Transferring Scene Files between the Camera and a Memory Stick (with the DXC-D50 Series)

When a DXC-D50-series camera is connected, the registered scene files can be stored as a data block and can be read when required.

Storing the scene files on a Memory Stick

Proceed as follows:

- 1** Insert the **Memory Stick** (*see page 59*).
- 2** Press the OTHERS button in the Menu operation block so that the OTHERS menu is displayed on the LCD, then press **[RCP Config]** to call the RCP Config menu.
- 3** Set the menu to Advanced Setting mode.
 - 1)** Press **[Security]** on the RCP Config menu.
 - 2)** Press and highlight **[Engineer Mode]**.

The **[Status]**, **[Menu Set]**, and **[Code No.]** buttons are displayed.
 - 3)** Press **[Status]**.

The Security Status menu appears.
 - 4)** Press **[Advance Mode]**.
- 4** Return to the OTHERS menu, and press **[File]**.
- 5** Press **[File Trans]**.

The Scene File Transfer display appears.
- 6** Press **[CAM -> MS]**.

A confirmation display appears.
- 7** Press **[Start]**.

The registered scene files are transferred to the **Memory Stick**.

When the transfer is finished

The termination message “COMPLETED” appears.

Reading the scene files from a Memory Stick

Proceed as follows:

- 1** Insert the **Memory Stick** (*see page 59*).
- 2** Operate in the same manner as when you stored the files until the Scene File Transfer display appears.
- 3** Press **[MS -> CAM]**.

A confirmation display appears.
- 4** Press **[Start]**.

The scene files are transferred from the **Memory Stick** to the connected camera.

When the transfer is finished

The termination message “COMPLETED” appears.

Operating Setup Files (for DXC-D30/D35 Series only)

Among the setting items listed in the table on pages 51 and 52, the settings for those items that have “yes” in the Setup-file column are stored as a setup file in the memory of the camera. In addition to five files (PRESET 1 to PRESET 5) that have already been registered in the camera, three more files (USER 1 to USER 3) can be registered and retrieved as required.

To register or retrieve setup files, use the Setup File operation display.

Registering a setup file

- 1 Press the OTHERS button in the menu operation block to display the OTHERS menu on the LCD, then press **[File]** to call the File menu.
- 2 Press **[Setup File]**.

The Setup File operation display appears.

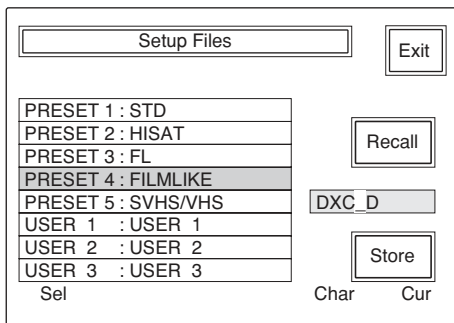

- 3 Turn the knob at the leftmost position (**Sel**) to select a file to which you wish to register data among USER 1 to USER 3 (user’s registration files 1-3) from the list.
- 4 Enter a filename (up to eight characters) in the filename input box.

Moving the cursor: Turn the rightmost knob (**Cur**) until the cursor comes to the position where you wish to enter a character.

Selecting a character: Turn the second knob (**Char**) from the right until the character which you wish to enter appears.

- 5 Press **[Store]**.

The current settings of the camera are stored as a setup file with the name entered in Step 4, and that filename is displayed on the list.

Retrieving a setup file

- 1 Call the Setup File operation display, then turn the knob at the leftmost position (**Sel**) to select the file you wish to retrieve from among PRESET 1 to PRESET 5 (preset files 1–5) and USER 1 to USER 3 (user’s registration files 1–3) from the list.
- 2 Press **[Recall]**.

The selected file is retrieved, and the settings of the camera are replaced with the data of the retrieved file.

Skin Detail Correction/Skin Matrix Adjustment (for DXC-D30/D35/D50 Series Only)

The skin detail and skin matrix functions can adjust detail level and matrix (saturation and hue) of a selected skin gate area (area designated by color range).

Once a skin gate area has been selected, it can be used as a target for both skin detail correction and skin matrix adjustment, and activation of each function can be performed independently.

Selecting the skin gate area

Normally, use the SKIN DTL SETUP button of the AUTO SETUP block to designate the skin gate position (target color) automatically.

- 1 Press and light the SKIN DTL SETUP button (ON).

The window which shows the skin gate and target area appears in the camera's viewfinder. You can also see the skin gate with a picture output from the CCU's PIX connector.

- 2 Press the START button.

The skin gate is designated automatically.

When using a DXC-D30/D35-series camera, you can manually adjust the position of the designated skin gate in Paint menu.

Performing skin detail correction

By skin detail correction, you can lower the detail level of the skin gate area to the detail level outside of the area.

- 1 Press and light the SKIN DETAIL button (ON).
- 2 Select **SKIN DETAIL** in Paint menu 2.
- 3 Set the detail correction level using the leftmost control knob (**Level**).

Setting the level to the max. value (+99): The detail level of the area is set to the lowest level.

Setting the level to the min. value (0): The detail level of the area is set to the same level with the outside of the area. (The same situation as the skin detail function is set to off.)

If you power off the unit or store the current settings as a scene file while setting the detail level to the minimum value, the skin detail function will be set to off when you power on the unit or recall the scene file next time.

To store the skin detail settings

Set the SKIN DETAIL button on before powering off the unit or storing the settings as a scene file. If the button is off, the skin detail settings will not be stored.

Performing skin matrix adjustment

Follow the procedure described below to adjust the matrix (saturation and hue) of the skin gate area.

- 1 Select **SKIN MATRIX** in Paint menu 3.
- 2 Set **SKIN MATRIX** to ON.
- 3 Set the saturation and hue using the leftmost control knob (**Hue**) or the second control knob (**Sat**) from the left.

Selecting 00 causes the same situation as the skin matrix function is set off.

If you power off the unit or store the current settings as a scene file while selecting 00, the skin matrix function will be set to off when you power on the unit or recall the scene file next time.

Note

When using the DXC-D30 series, this adjustment is valid when the matrix adjustment function is active.

To store the skin matrix settings

Activate both the matrix adjustment and skin matrix adjustment functions before powering off the unit or storing the settings as a scene file. Otherwise, the skin matrix settings will not be stored.

Multi-Camera Control

Connections and Preparatons

In a multi-camera system, connecting all the CCU-TX7 units via the RS232C connectors allows one RCP unit selected from all the RCP units in the system to control the multiple cameras.

If the selected unit is set as the master unit and the rest are set as slave units, the setting data of the camera connected to the master unit can be transferred to other cameras.

To make connections among the CCU-TX7 units

Connect RS-232C cross (or reverse) cables with D-sub 25-pin plugs (not supplied) to the RS232C connectors on each CCU to make a daisy chain of the CCUs.

For more information about cables which can be used, consult your Sony dealer.

Notes

- It is impossible to assure that all the cameras can be set up to the same conditions under the multi-camera control. Setting purposes and the current condition of each camera may cause variation of the setting condition.
- In a system which contains more than two types of cameras, the setting items, adjustment range and adjustment accuracy available at the multi-camera operation are determined depending on the efficiency of the camera connected to the master unit.
- There are two setting modes: Absolute mode and Relative mode.
- Settings performed on a slave unit are valid only to the connected camera.

Setting a unit to the master unit or a slave unit

Note

Perform the following procedure after making sure all the cameras in the system are powered on. Note that executing the procedure when there is any cameras powered off may result in failure.

- 1** Select one RCP unit for the master unit, and press the MASTER button. (The button lights when pressed.)
- 2** Select one RCP unit (or more) for a slave unit, and press the SLAVE button. (The button lights when pressed.)

Adjusting the Iris/Master Black of Multiple Cameras at One Time

For iris and master black adjustments, you can use any one of the RCP units (whether it is the master unit or a slave unit) specified with the IRIS/M.BLACK LINK button.

- 1** Select the cameras for which you will adjust the iris or master black by pressing the IRIS/M.BLACK LINK buttons on the connected RCP units. (The buttons light when pressed.)
- 2** Adjust the iris or master black on one RCP unit whose IRIS/M.BLACK LINK button lights.

On the cameras connected to the RCP units whose IRIS/M.BLACK LINK buttons light, the iris or master black adjustments are performed by the same amount and at the same time (on relative mode).

Note

The IRIS/M.BLACK LINK function is released while transferring the scene files.

Data Transfer Among Multiple Cameras

The settings made on the master unit can be transferred to the cameras connected to the slave units, if they can be registered as a scene file.

Perform as follows:

- 1** Select **[File]** from the OTHERS menu, and press **[Copy to Slaves]**.
- 2** Press **[Start]**.

Data transfer begins.

Meanwhile, on all the linked RCP units (including units selected as neither the master unit nor slave units), the message "IN PROGRESS" is displayed on the LCD and all buttons and knobs are locked.

When the data transfer completes, the message "COMPLETED" appears on the LCD. The LCD soon returns to the original status.

Multi-Camera Control

Notes

- While scene file transfer is in progress on a slave unit, do not transfer data from the master unit to the slave unit. Scene file transfer will fail.
- The master/slave setting is released while transferring the scene files.

Operating Multiple Cameras from One RCP Unit —Command Link

Command link allows one RCP selected as the master unit to control the adjustments or settings of the cameras connected to the slave units.

To perform command link operation, activate the command link on the Command Link operation display on the master unit.

Notes

The Command Link operation display can be displayed from the RCP Config menu only in Advanced Setting mode.

Command Link items

- Gain setting (Absolute mode)
- Shutter settings (Absolute mode)
 - Shutter on/off
 - Clear scan mode on/off
 - EVS function on/off
 - Shutter speed
 - Clear scan frequency
- R/B manual white balance adjustment (Relative mode)
- R/B manual black balance adjustment (Relative mode)
- R/G/B manual flare correction (Relative mode)

Notes

- Do not perform command link operation in a system containing multiple cameras of different types. If the camera connected to a slave unit is different in type from the camera connected to the master unit, changing the gain value on the master unit will set the gain value of the camera connected to the slave unit to 0 dB or the LOW position. The CLS frequency does not exceed the limit for the camera.
- When adjusting the white balance, black balance and flare with the command link, select Manual Adjustment mode for white balance, black balance and flare also on slave units.

- The command link adjustment of R/G/B flare correction is available only with the DXC-D30/D35/D50 series.

Activating command link adjustments/settings

- 1 Press the OTHERS button in the Menu operation block so that the OTHERS menu is displayed on the LCD, then press **RCP Config** to call the RCP Config menu.
- 2 Set the menu to Advanced Setting mode.
 - 1) Press **Security** on the RCP Config menu.
 - 2) Press and highlight **Engineer Mode**.
The **Status**, **Menu Set**, and **Code No.** buttons are displayed.
 - 3) Press **Status**.
The Security Status menu appears.
 - 4) Press **Advance Mode**.
- 3 Return to the RCP Config menu, and press **Comm Link**.

The Command Link Items are displayed.

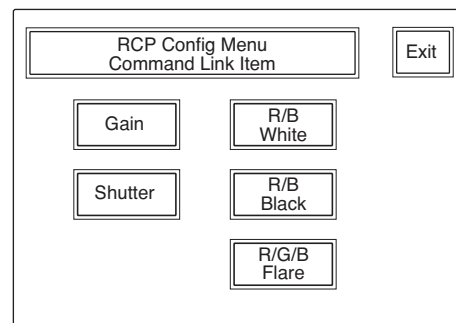

- 4 Press and highlight the button for the item for which you wish to activate the command link.
- 5 Press **Exit** to leave the menu.

When you adjust the item for which you wish to activate the command link on the master unit, the adjustment becomes valid on the cameras connected to the slave units.

Memory Sticks

Using a Memory Stick

When a **Memory Stick** is inserted in the panel, the file data can be stored on the **Memory Stick**, which enables you to share data among RCPs.

Inserting a Memory Stick

Insert a **Memory Stick** with the label side to the left into the **Memory Stick** slot until it clicks and the access lamp lights in red.

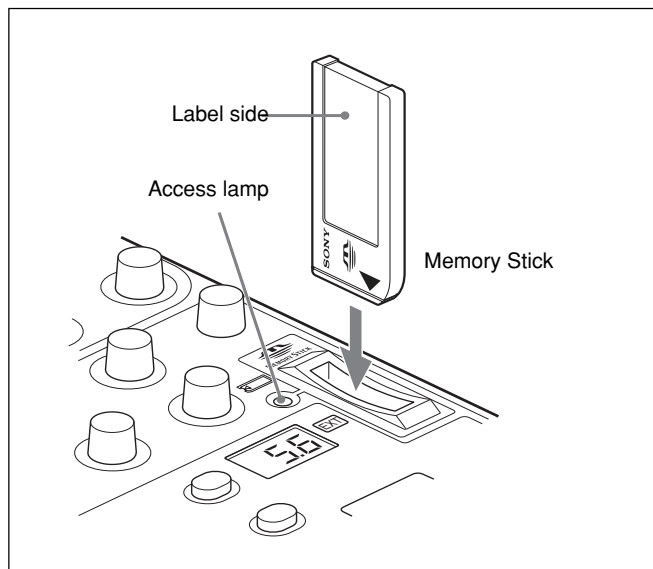

Note

Never insert/remove a **Memory Stick** while the access lamp is lit in red.

To remove a Memory Stick

If you push the inserted **Memory Stick**, the **Memory Stick** will pop out a little. Then pull the **Memory Stick** out.

Access lamp

The access lamp shows the status of the **Memory Stick**.

Off: No **Memory Stick** is inserted.

Lit in green: There is a **Memory Stick** in the slot. In this condition, you can safely eject the **Memory Stick**.

Lit in red: Data are being read/written. If you eject the **Memory Stick** in this condition, the data are not guaranteed. All the data may be lost.

We recommend backing up important data.

Notes on Memory Stick

On Memory Stick

Memory Stick is a new compact, portable and versatile IC recording medium with a data capacity that exceeds that of a floppy disk. **Memory Stick** is specially designed for exchanging and sharing digital data among **Memory Stick** compatible products. Because it is removable, **Memory Stick** can also be used for external data storage.

Types of Memory Stick

There are two types of **Memory Stick**: “MagicGate Memory Stick” that are equipped with the MagicGate copyright protection technology and general “Memory Stick.” You can use either type of **Memory Stick** with your camera. However, because your camera does not support the MagicGate standards, data recorded with your camera is not subject to MagicGate copyright protection.

On MagicGate

MagicGate is copyright-protection technology that uses encryption technology.

Structure of Memory Stick

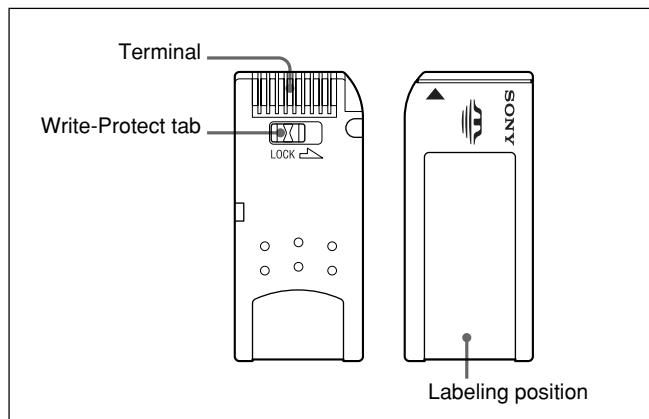

You cannot record or erase data when the write-protect tab on the **Memory Stick** is set to **LOCK**.

Memory Sticks

Handling of Memory Stick

- Image data may be damaged in the following cases:
 - If you remove the **Memory Stick**, or turn the power off when the access lamp is lit in red
 - If you use a **Memory Stick** near static electricity or a magnetic field

We recommend backing up important data.

- Prevent metallic objects or your finger from coming into contact with the terminal of the connecting section.
- Do not attach any material other than the supplied label to the label space.
- Attach the label at the prescribed labeling position. Make sure the label is attached at the labeling position properly.
- Do not bend, drop, or apply strong shock to a **Memory Stick**.
- Do not disassemble or modify a **Memory Stick**.
- Do not let the **Memory Stick** get wet.
- Do not use or keep a **Memory Stick** in locations that are:
 - Extremely hot such as in a car parked in the sun
 - Under direct sunlight
 - Very humid or subject to corrosive gases
- When you carry or store a **Memory Stick**, keep it in its case.
- **Memory Sticks** of the sizes that can be used with the RCP-D50/D51 may not be used with some cameras. To exchange the setting data with a camera via a **Memory Stick**, be sure to use **Memory Sticks** of a size that can be used with both the RCP-D50/D51 and the camera.

Memory Stick and  are the trademarks of Sony Corporation.
MagicGate Memory Stick and **MAGICGATE** are the trademarks of Sony Corporation.

Specifications

General

Power requirements	10.5 to 17 V DC
Power consumption	4.5 W
Cable length	50 m (164 feet) max. (when the CCA-7 cable is used)
Operating temperature	5°C to 40°C (41°F to 104°F)
Dimensions (w/h/d)	RCP-D50: 102 × 354 × 126.5 mm (4 1/8 × 14 × 5 inches) RCP-D51: 102 × 354 × 86.5 mm (4 1/8 × 14 × 3 1/2 inches)
Mass	RCP-D50: 1.5 kg (3 lb 5 oz) RCP-D51: 1.3 kg (2 lb 14 oz)

Inputs/outputs

CCU/CAMERA	10-pin multiconnector (1)
MONITOR	BNC type (1)
EXT I/O	9-pin D-sub connector (1)

Supplied accessories

Remote cable CCA-7-5 (5 m) (1)
Operating instructions (1 set)

Optional accessories

Remote cable CCA-7-5 (5 m)
Remote cable CCA-7-25 (25 m)
Memory Stick

Design and specifications are subject to change without notice.

