

HD Camera Control Unit

Operating Instructions

Before operating the unit, please read this manual thoroughly and retain it for future reference.

HXCU-100

For the HXCU-100

WARNING

To reduce the risk of fire or electric shock, do not expose this apparatus to rain or moisture.

To avoid electrical shock, do not open the cabinet. Refer servicing to qualified personnel only.

THIS APPARATUS MUST BE EARTHED.



This symbol is intended to alert the user to the presence of important operating and maintenance (servicing) instructions in the literature accompanying the appliance.

WARNING: THIS WARNING IS APPLICABLE FOR USA ONLY.

If used in USA, use the UL LISTED power cord specified below.

DO NOT USE ANY OTHER POWER CORD.

Plug Cap	Parallel blade with ground pin (NEMA 5-15P Configuration)
Cord	Type SJT, three 16 or 18 AWG wires
Length	Minimum 1.5 m (4 ft. 11in.), Less than 2.5 m (8 ft. 3 in.)
Rating	Minimum 10A, 125V

Using this unit at a voltage other than 120V may require the use of a different line cord or attachment plug, or both. To reduce the risk of fire or electric shock, refer servicing to qualified service personnel.

WARNING: THIS WARNING IS APPLICABLE FOR OTHER COUNTRIES.

1. Use the approved Power Cord (3-core mains lead)/Appliance Connector/Plug with earthing-contacts that conforms to the safety regulations of each country if applicable.
2. Use the Power Cord (3-core mains lead)/Appliance Connector/Plug conforming to the proper ratings (Voltage, Ampere).

If you have questions on the use of the above Power Cord/ Appliance Connector/Plug, please consult a qualified service personnel.

For kundene i Norge

Dette utstyret kan kobles til et IT-strømfordelingssystem.

For the customers in the U.S.A.

This equipment has been tested and found to comply with the limits for a Class A digital device, pursuant to Part 15 of the FCC Rules. These limits are designed to provide reasonable protection against harmful interference when the equipment is operated in a commercial environment. This equipment generates, uses, and can radiate radio frequency energy and, if not installed and used in accordance with the instruction manual, may cause harmful interference to radio communications. Operation of this equipment in a residential area is likely to cause harmful interference in which case the user will be required to correct the interference at his own expense.

You are cautioned that any changes or modifications not expressly approved in this manual could void your authority to operate this equipment.

All interface cables used to connect peripherals must be shielded in order to comply with the limits for a digital device pursuant to Subpart B of Part 15 of FCC Rules.

For the customers in Europe

This product with the CE marking complies with both the EMC Directive and the Low Voltage Directive issued by the Commission of the European Community.

Compliance with these directives implies conformity to the following European standards:

- EN60950-1:Product Safety
- EN55103-1: Electromagnetic Interference (Emission)
- EN55103-2: Electromagnetic Susceptibility (Immunity)

This product is intended for use in the following Electromagnetic Environment: E4 (controlled EMC environment, ex. TV studio).

For the customers in Europe, Australia and New Zealand

WARNING

This is a Class A product. In a domestic environment, this product may cause radio interference in which case the user may be required to take adequate measures.

For the customers in Europe

The manufacturer of this product is Sony Corporation, 1-7-1 Konan, Minato-ku, Tokyo, Japan.

The Authorized Representative for EMC and product safety is Sony Deutschland GmbH, Hedelfinger Strasse 61, 70327 Stuttgart, Germany. For any service or guarantee matters please refer to the addresses given in separate service or guarantee documents.

This apparatus shall not be used in a residential area.

For the State of California, USA only

Perchlorate Material - special handling may apply, See www.dtsc.ca.gov/hazardouswaste/perchlorate
Perchlorate Material : Lithium battery contains perchlorate.

For the customers in Taiwan only



廢電池請回收

For the HKCU-FP1

For the customers in Europe

This product with the CE marking complies with the EMC Directive issued by the Commission of the European Community.

Compliance with this directive implies conformity to the following European standards:

- EN55103-1: Electromagnetic Interference (Emission)
- EN55103-2: Electromagnetic Susceptibility (Immunity)

This product is intended for use in the following Electromagnetic Environment: E4 (controlled EMC environment, ex. TV studio).

For the customers in Europe, Australia and New Zealand

WARNING

This is a Class A product. In a domestic environment, this product may cause radio interference in which case the user may be required to take adequate measures.

For the customers in Europe

The manufacturer of this product is Sony Corporation, 1-7-1 Konan, Minato-ku, Tokyo, Japan.

The Authorized Representative for EMC and product safety is Sony Deutschland GmbH, Hedelfinger Strasse 61, 70327 Stuttgart, Germany.

This apparatus shall not be used in a residential area.

Table of Contents

- Overview 5**
 - Features 5
 - System Configuration Example 6
- Locations and Functions of Parts 7**
 - Front Panel 7
 - Rear Panel 8
 - HKCU-FP1 CCU Control Panel (Optional) 10
- Status Display 12**
 - Displaying the Status Screen 12
 - Status Display Screen 12
- Setup Menu 15**
 - Changing Menu Item Settings 15
 - Menu List 17
- Appendix 26**
 - Notes on Use 26
 - Digital Triax Transmission 26
 - Error Messages 26
 - Return Signal Combinations 26
 - License Declarations 27
 - Specifications 27

Overview

The HXCU-100 Camera Control Unit connects to a Sony HXC-100 HD color camera. It performs signal processing, provides an interface for external equipment, and supplies power to the camera.

The CCU features a down converter which converts HD¹⁾ signals from a camera to SD²⁾ signals, and a simplified return video up converter which converts SD signals to HD signals. It is compatible with both HD camera system and SD camera system formats, making it flexible to use.

1) HD (High Definition) signal: Name for 1125/750-line HDTV signals

2) SD (Standard Definition) signal: Name for NTSC/PAL, 525/625 component, and 525/625 composite signals

The CCU can be combined with an RCP-700/900 Remote Control Panel (optional) to form a camera control system. The CCU also supports an HKCU-FP1 CCU Control Panel (optional) which can be mounted on the front of the CCU to form a simple remote control system.

Features

Multi-system input/output interface

The HXCU-100 is equipped with the following input and output signal connectors as standard equipment.

Video outputs

- SDI (main), 2-system (HD/SD selectable, embedded digital audio)
- SDI (monitor), 2-system (HD/SD selectable, embedded digital audio, superimposed character and marker display)
- Analog composite (VBS 2-system, PIX 1-system, WF 1-system)
- Analog component, 1-system (HD Y/Pb/Pr, HD R/G/B, SD Y/R-Y/B-Y, SD R/G/B 4-format selectable)
- Sync, 1-system (HD/SD selectable)

Video inputs

- Reference input (HD/SD selectable)
- SDI return input, 2-system (HD/SD selectable)
- VBS return input, 2-system
- VBS teleprompter input, 1-system

Audio input/outputs

- Microphone (analog) output, 2-system (XLR-3-pin)
- Intercom input/output, 2-system (D-sub 25-pin)
- PGM (program audio) input, 2-system (D-sub 25-pin)

Other input/outputs

- Tally (R/G)
- Microphone remote (D-sub 15-pin)
- WF (waveform monitor) remote output (D-sub 15-pin)
- WF (waveform monitor) mode output (4-pin)
- Trunk (D-sub 9-pin)
- REMOTE (8-pin)
- LAN (RJ-45, 8-pin)

External sync signals

The CCU can be locked to an external sync signal. Either an HD tri-level sync signal or an SD sync (black burst) signal can be used as the sync signal.

Digital triax transmission

The CCU and camera are connected using the industry-standard double-shielded triaxial camera cable (commonly referred to as triax). The camera and CCU are equipped with the latest Sony-developed digital transmission technology which can transmit high-resolution pictures between the camera and CCU, regardless of the cable length.

Built-in down converter

HD signals from the camera can be converted to high-resolution SD component SDI output signals using the wideband down converter. The output signal aspect ratio can be set to 4:3 edge crop, 16:9 squeeze, or letterbox. The down converted SD signal has independent image enhancement, gamma, and matrix functions that can be controlled externally.

Built-in simplified up converter

SD signal return video is displayed in the HD viewfinder using a simple up converter. The return video aspect ratio can be set to 4:3 edge crop, 16:9 squeeze, or letterbox.

Electric shock prevention

A safety function cuts the high-voltage supply from the CCU if the connection to the camera becomes unsafe.

When power is applied, low-voltage power is first supplied to the camera. After the connected camera is correctly identified using tone signal detection, the regular DC180 V high-voltage power is supplied to the camera. Power is not supplied to cameras not connected via the triax cable.

Alarm indicators are also fitted to indicate cable open-circuit and short-circuit conditions.

Wide range of audio functions

The CCU is fitted with two-channel microphone output, video signals with embedded audio, and PGM (program) audio input/output connectors. It also features an intercom system with two independent channels, and supports four-wire and RTS/Clear-Com intercom systems.

For information on support for RTS/Clear-Com systems, contact a Sony service or sales representative.

Microphone volume control

The camera's microphone volume can be controlled via the MIC REMOTE connector.

Character monitor signal output

The self-diagnosis status screens and setup menu can be output as a text character display on the video output signal. See "Video outputs" on page 5.

Rack mountable

The CCU can be installed in a standard EIA 19-inch rack. The height of the unit is 1.5U.

HKCU-FP1 CCU Control Panel (optional)

The HKCU-FP1 is a control panel that can be mounted in place of the standard front panel on the CCU. Operating switches and knobs are used to adjust the basic CCU functions. The control panel is connected to the CCU using only 5 screws and an internal wiring harness for easy installation and removal.

System Configuration Example

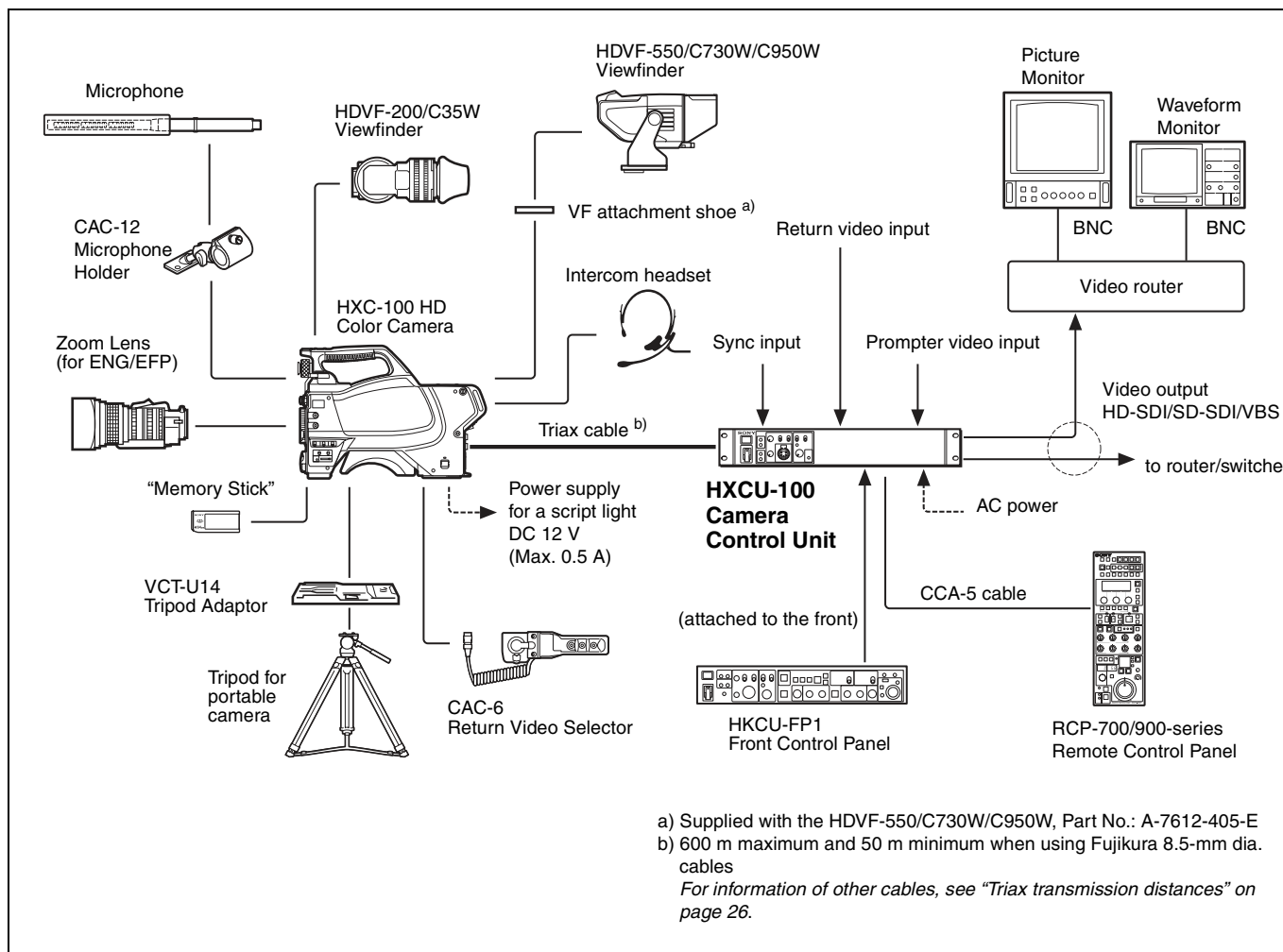

Locations and Functions of Parts

Front Panel

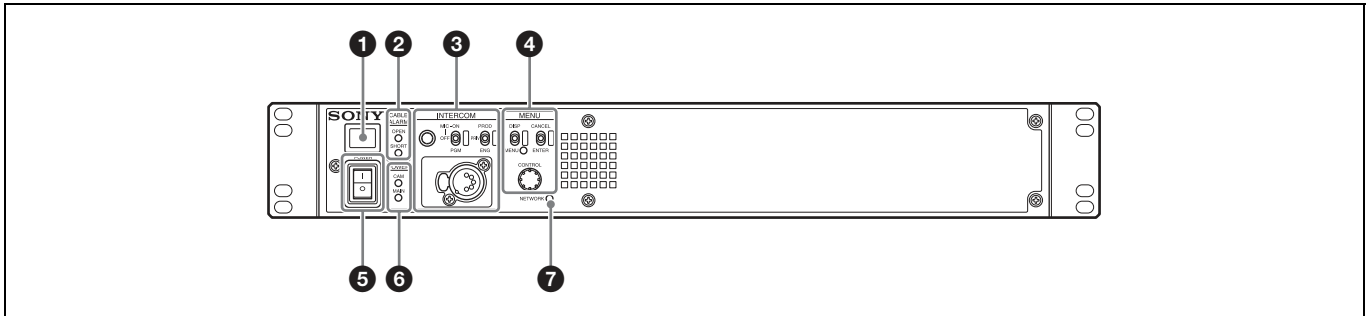

1 Tally light

Turns on red to indicate a red tally signal is being received (such as when the picture from the camera connected to the CCU is being used). When the CALL button on the camera, the MSU-900 series Master Setup Unit, or the RCP-700/900 series Remote Control Panel is pressed, the light turns off if lit or turns on if not lit.

Turns on green to indicate a green tally signal is being received.

A number plate supplied with the CCU can be attached here (see the following figure).

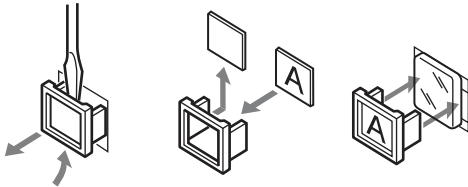

2 CABLE ALARM indicators

OPEN: Turns on when a camera is not connected (open circuit) to the CAMERA connector on the rear panel via a triax cable. While on, the CCU does not supply any power to the camera.

It flashes when there is a problem with the transmission between the camera and the CCU.

Note

It may also turn on when using the camera with an external DC supply.

SHORT: Turns on when there is an overcurrent condition (short circuit) on the triax cable. While on, the CCU does not supply any power to the camera.

3 INTERCOM audio input/output and control block

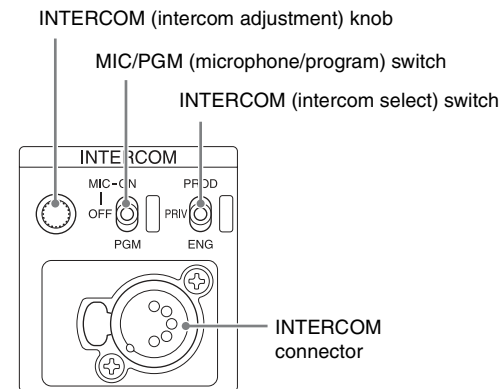

- **INTERCOM (intercom adjustment) knob**

Adjusts the headset audio level.

- **MIC/PGM (microphone/program) switch**

ON: Turns the headset microphone on.

OFF: Turns the headset microphone off.

PGM: Selects program audio output. In this mode, the INTERCOM knob adjusts the headset program audio level.

- **INTERCOM (intercom select) switch**

Selects the intercom signal input/output connection source for the INTERCOM connector on the rear panel.

PROD: Connects the producer line.

PRIV: Disconnects both the producer line and engineer line, allowing private communication between CCU and camera only.

ENG: Connects the engineer line.

- **INTERCOM connector (XLR 5-pin)**

Intercom headset connection.

4 MENU control block

DISP/MENU (display/menu) lever and indicator

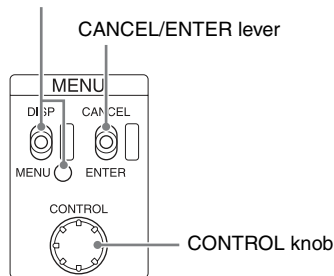

- **DISP/MENU (display/menu) lever and indicator**

Selects the status display or setup menu display. In setup menu mode, the indicator turns on.

- **CANCEL/ENTER lever**

In setup menu mode, used to cancel and enter settings.

- **CONTROL knob (rotary encoder)**

In status screen mode, used to change the displayed page. In setup menu mode, used to move the cursor on a page and to change menu settings. Pressing the CONTROL knob performs the same function as setting the CANCEL/ENTER lever to the ENTER position.

5 POWER switch

Switches the power for the entire system on and off, including the CCU, camera, and the RCP-700/900 series Remote Control Panel connected to the REMOTE connector on the rear panel. Pressing the “I” side turns the camera system on, and pressing the “O” side turns it off.

6 POWER indicator

CAM: Turns on when power is supplied to the camera.

MAIN: Turns on when the CCU power supply is turned on. It flashes when there is a problem with the fan.

7 NETWORK indicator

Displays the network system connection status.

On: Indicates that external control equipment (MSU-900 series Master Setup Unit, RCP-900 series Remote Control Panel, or other device) is connected.

Flashing: Indicates a connection problem with the external control equipment (MSU-900 series Master Setup Unit, RCP-900 series Remote Control Panel, or other device).

Off: Indicates that a LAN cable is not connected or that the network system connection parameters have not been set.

See “Network diagnostics” on page 13 and “NETWORK SETTINGS menu” on page 25.

Rear Panel

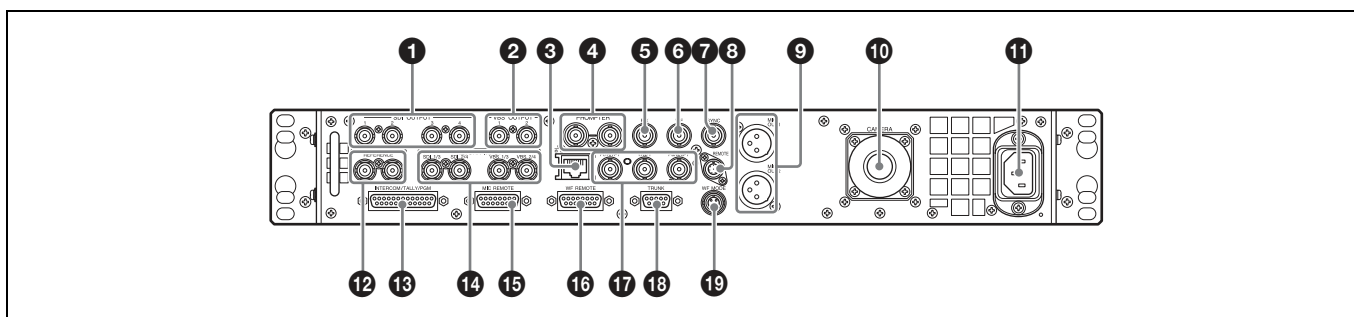

- **1 SDI OUTPUT 1 to 4 connectors (BNC type)**

Outputs the camera signals in HD SDI or SD SDI signal format.

The SDI OUTPUT 3 and SDI OUTPUT 4 connectors can also output signals with superimposed character or marker display.

- **2 VBS OUTPUT 1, 2 (composite video signal 1, 2) connectors (BNC type)**

Outputs (2-system) the camera signals in composite signal format.

- **3 LAN jack (RJ-45, 8-pin)**

Connects to a LAN hub (10BASE-T/100BASE-TX), when using a network connection, via a LAN cable (shielded type, category 5 or higher).

CAUTION

- For safety, do not connect the connector for peripheral device wiring that might have excessive voltage to this port. Follow the instructions for this port.
- When you connect the LAN cable of the unit to peripheral device, use a shielded-type cable to prevent malfunction due to radiation noise.

- **4 PROMPTER (teleprompter input) connectors (BNC type)**

Inputs the VBS signal for the teleprompter. The input signal is output from the other connector as-is (loop-through output). If the loop-through output is not used, connect it to a 75 Ω terminator.

- **5 PIX (picture monitor output) connector (BNC type)**

Outputs a video signal for a picture monitor. It can also output a signal with superimposed character display.

- **6 WF (waveform monitor output) connector (BNC type)**

Outputs a video signal for a waveform monitor.

- **7 SYNC (sync signal output) connector**

Outputs a sync signal for connection to the sync signal input connector of a waveform monitor or picture monitor.

- **8 REMOTE connector (8-pin)**

Transmits and receives control signals from a MSU-900 series Master Setup Unit or RCP-700/900 series Remote Control Panel via a CCA-5 cable (optional). It also supplies power when connected to an RCP-700/900 series Remote Control Panel.

9 MIC OUT1, MIC OUT2 (microphone output 1, 2) connectors (XLR 3-pin)

Outputs the camera microphone signals.

10 CAMERA connector (triax connector)

Connects to the camera via a triax cable. The camera sends all video and audio signals to the CCU, and the CCU sends control signals, return video and audio signals, as well as power, to the camera over a single triax cable.

11 AC supply input connector

Connects to the AC supply via the specified power cord (optional). A plug holder (optional) can be used to secure the power cord to the CCU.

12 REFERENCE (reference input) connectors (BNC type)

Inputs an HD tri-level reference sync signal or SD reference sync signal (black burst signal) on either of the two connectors. The input signal is output from the other connector as-is (loop-through output). If the loop-through output is not used, connect it to a 75 Ω terminator.

13 INTERCOM/TALLY/PGM (intercom/tally/program audio) connector (D-sub 25-pin)

Transmits and receives the various intercom, tally, and program audio signals. It connects to the intercom/tally/program audio connector of the intercom system.

14 RETURN INPUT (return video input) connector block

- SDI 1/3, 2/4 (SDI return video 1/3, 2/4 input) connectors (BNC type)
- VBS 1/3, 2/4 (VBS return video 1/3, 2/4 input) connectors (BNC type)

Inputs the HD SDI return video signals and SD SDI return video signals (2-system), and the VBS return video signals (2-system).

For information on the return video signal combinations, see "Return Signal Combinations" on page 26.

15 MIC REMOTE (microphone remote) connector (D-sub 15-pin)

Connects to an external control device, such as an audio mixer, which can select the camera microphone gain to one of five values (20/30/40/50/60 dB) in response to the audio conditions when shooting.

This connector can also output a red tally signal and green tally signal.

16 WF REMOTE (waveform monitor remote) connector (D-sub 15-pin)

Outputs signals for a waveform monitor when controlling the waveform monitor display remotely from the MSU-900 series Master Setup Unit or RCP-700/900 series Remote Control Panel. It connects to a recall-type waveform monitor.

For connection details, refer to the waveform monitor manual.

17 Pr/R/R-Y, Y/G/Y, Pb/B/B-Y (component signals) connectors (BNC type)

Outputs the HD component signals, SD component signals, HD RGB signals, or SD RGB signals from the corresponding connectors.

18 TRUNK connector (D-sub 9-pin, RS-422A standard)

Connects to an external device to provide a communication path via the CCU between that device and another external device connected to the REMOTE connector on the camera.

19 WF MODE (waveform monitor mode output) connector (4-pin)

Connects to a waveform monitor and is used when monitoring each of the 3 R/G/B waveforms simultaneously in sequential mode.

When the SEQ button on the MSU-900 series Master Setup Unit or RCP-700/900 series Remote Control Panel is pressed, the video signal output from the WF connector changes to a sequence signal.

HKCU-FP1 CCU Control Panel (Optional)

The switches and knobs not described below are identical to those on the front panel. See "Front Panel" on page 7.

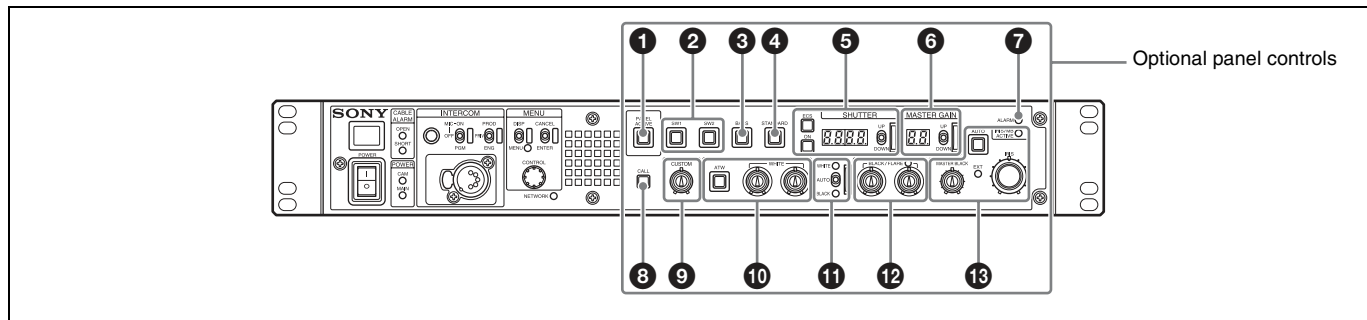

1 PANEL ACTIVE button

Activates the optional HKCU-FP1 CCU Control Panel to control the camera connected to the CCU (panel active state). When the button is lit, the IRIS/MB ACTIVE indicator also turns on simultaneously. When the button is not lit, the optional panel is deactivated (lock state) to prevent inadvertent operation.

2 SW1, SW2 (assignable switch 1, 2) buttons

Controls the function assigned to each button on the <FRONT PANEL 1> page in the CCU CONFIGURATION menu. The button light turns on/off as the assigned function is switched on/off.

See "ASSIGNABLE/CUSTOM" on <FRONT PANEL 1> on page 23.

3 BARS (color bars) button

Switches on the color bar signal output to the monitor connected to the CCU (button light turns on). Pressing the button again restores the previous signal output.

4 STANDARD button

Stores the current camera settings as the reference file data values in the camera (button light turns on for a few seconds). While the button is lit, pressing the button again cancels the operation and restores the previous data values.

5 SHUTTER controls

Controls the shutter settings.

ON button

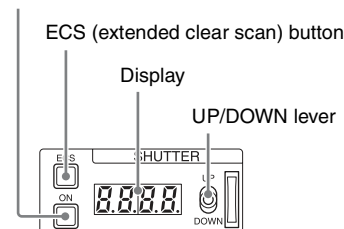

• ON button

Switches the normal shutter function on/off (button light turns on/off).

• ECS (extended clear scan) button

Switches the extended clear scan function on/off (button light turns on/off).

• Display

When the ECS button is lit: Displays the clear scan frequency. When the ON button is lit: Displays the shutter speed.

• UP/DOWN lever

When the ECS button is lit: Adjusts the clear scan frequency. UP increases the frequency, and DOWN decreases the frequency.

When the ON button is lit: Adjusts the shutter speed. UP increases the shutter speed, and DOWN decreases the shutter speed.

Holding the lever UP or DOWN advances the setting in that direction.

6 MASTER GAIN controls

Controls the video output signal gain in response to the lighting of the subject.

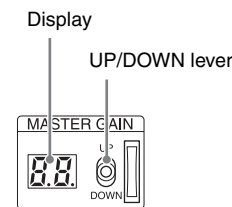

• Display

Displays the video output signal gain setting (dB units).

• UP/DOWN lever

Adjusts the video output signal gain setting (dB units).

UP increases the gain, and DOWN decreases the gain.

Holding the lever UP or DOWN advances the setting in that direction.

7 ALARM indicator

Lights up red to indicate an error in the CCU or camera system.

8 CALL button

Sends a call signal to the camera connected to the CCU and any external controller (such as the MSU-900 series Master Setup Unit or RCP-700/900 series Remote Control Panel).

The CALL button is commonly used to raise the camera operator or external control equipment operators on the intercom.

9 CUSTOM (custom volume) knob

Controls the function assigned to the knob on the <FRONT PANEL 1> page in the CCU CONFIGURATION menu. Turning the knob adjusts the assigned function.

See "VOLUME" on <FRONT PANEL 1> on page 24 and "CUSTOM" on <FRONT PANEL 2> on page 24.

10 White balance adjustment controls

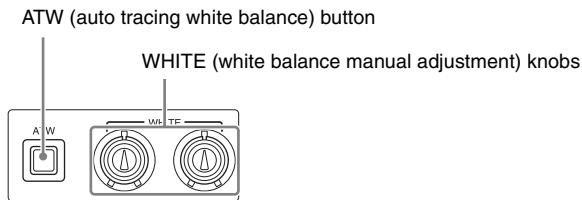

• ATW (auto tracing white balance) button

Switches the white balance auto adjustment function on/off (button light turns on/off). The white balance is automatically adjusted in response to the lighting conditions.

• WHITE (white balance manual adjustment) knobs

Adjusts the white balance manually. The left knob adjusts the R coefficient, and the right knob adjusts the B coefficient. The adjustment can be set to relative or absolute value mode on the <FRONT PANEL 1> page in the CCU CONFIGURATION menu. The default value is relative value mode.

See "R/B WHITE" on <FRONT PANEL 1> on page 24 and "R/B WHITE" on <FRONT PANEL 2> on page 24.

Note

When the ATW button is lit, the WHITE knobs are deactivated.

11 AUTO WHITE/BLACK (white balance/black balance auto adjustment) lever

Initiates the white balance or black balance auto adjustment function.

WHITE automatically adjusts the white balance, and BLACK automatically adjusts the black balance.

Notes

- When the WHITE knobs are set to absolute value mode, the white balance cannot be automatically adjusted using the AUTO WHITE/BLACK lever.
- When the BLACK/FLARE indicator is not lit and the BLACK/FLARE knobs are set to absolute value mode, the black balance cannot be automatically adjusted using the AUTO WHITE/BLACK lever.

12 BLACK/FLARE (black balance/flare balance manual adjustment) knobs and indicator

Adjusts the black balance and flare balance manually. When the indicator is not lit, the knobs adjust the black balance.

When the indicator is lit, the knobs adjust the flare balance.

The left knob adjusts the R coefficient, and the right knob adjusts the B coefficient.

The indicator operating mode (on/off function) can be set on the <FRONT PANEL 1> page in the CCU CONFIGURATION menu.

The adjustment can be set to black balance or flare balance adjustment in relative or absolute value mode on the <FRONT PANEL 1> page in the CCU CONFIGURATION menu. The default value is black balance adjustment in relative value mode.

See "R/B BLACK" on <FRONT PANEL 1> on page 24 and "R/B BLACK" on <FRONT PANEL 2> on page 24.

13 IRIS/MASTER BLACK adjustment controls

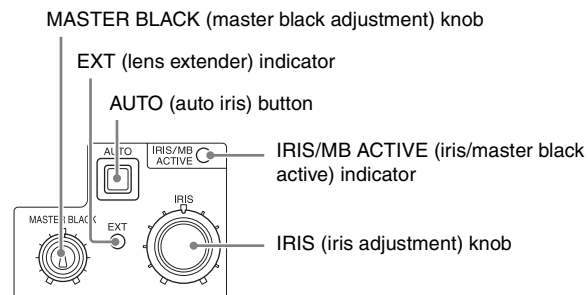

• MASTER BLACK (master black adjustment) knob

Adjusts the master black manually.

The adjustment can be set to relative or absolute value mode on the <FRONT PANEL 1> page in the CCU CONFIGURATION menu. The default value is relative value mode.

See "M BLACK" on <FRONT PANEL 1> on page 24 and "M BLACK" on <FRONT PANEL 2> on page 24.

• EXT (lens extender) indicator

Turns on to indicate that the lens extender is in-use on the camera.

• AUTO (auto iris) button

Switches the lens auto iris adjustment function on/off (button light turns on/off). The iris is automatically adjusted in response to the input light level.

When the button is not lit, the iris is adjusted manually.

• IRIS/MB ACTIVE (iris/master black active) indicator

Indicates, when lit, that the iris and master black controls are active (in panel active state set by the PANEL ACTIVE button). When the indicator is lit, the iris and master black can be adjusted from the CCU.

• IRIS (iris adjustment) knob

When the AUTO button is not lit: Adjusts the lens iris manually.

When the AUTO button is lit: Finely adjusts the auto adjusted iris value.

The adjustment can be set to relative or absolute value mode on the <FRONT PANEL 1> page in the CCU CONFIGURATION menu. The default value is relative value mode.

See "IRIS" on <FRONT PANEL 1> on page 24 and "IRIS" on <FRONT PANEL 2> on page 24.

Status Display

The CCU system status can be monitored using a picture monitor connected to the PIX output.

For information on monitoring and changing settings, see “Setup Menu” on page 15.

Displaying the Status Screen

The status screen is controlled using the knob and levers in the MENU control block on the front panel.

DISP/MENU lever and indicator

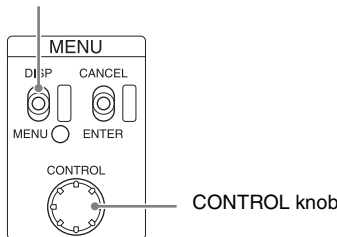

To display the status screen

Set the DISP/MENU lever to the DISP position. The most recently viewed status screen page is displayed (when first powered on, the camera settings page is displayed). Turning the CONTROL knob changes the displayed page.

To exit the status screen display

In status screen display mode, set the DISP/MENU lever to the DISP position.

Status Display Screen

The following information is displayed on the status display screen.

- Camera settings
- System status
- CCU hardware diagnostics
- Camera system diagnostics
- Network diagnostics
- CCU SY board diagnostics
- CCU DPR board diagnostics
- Front panel diagnostics (displayed only when the HKCU-FP1 CCU Control Panel is fitted)
- Camera hardware diagnostics
- ROM version information for major components

Camera settings

Page 1

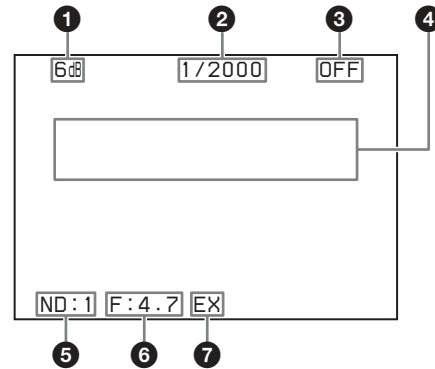

1 Master gain value

Video output signal gain (dB units)

2 Shutter speed/Clear scan frequency

Shutter speed value. When ECS is on, the clear scan frequency is displayed.

3 Shutter/ECS

Shutter/ECS on/off indicator

4 Camera auto control information area

Top: Displays the Auto Setup category and execution status

Bottom: Displays the execution item

5 ND filter

Current ND filter selection

6 F-stop value

Lens f-stop value (iris value)

7 EX (lens extender)

Lens extender indicator

Notes

- Items that are turned off using the <DISPLAY> page settings of the CCU CONFIGURATION menu are not displayed.
- A “-” mark is displayed for each item when a camera is not connected.

Page 2

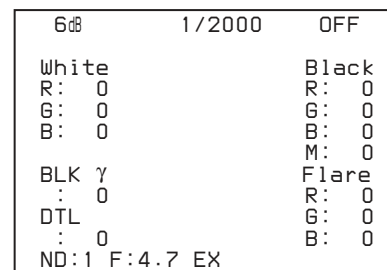

White: White balance R/G/B value

Black: Black balance R/G/B/Master value

BLK γ : Black gamma value

Flare: Flare balance R/G/B value

DTL: Detail level

Note

The items along the bottom edge are common to both pages 1 and 2.

System status

```
*System Status*      1/12
HXC-100      1080/59.94I
Reference:Free Lock
SDI-1/2      :1080/59.94I
SDI-3/4      :525/59.94I
Component:SD YCD
Return1      :1080/59.94I
Return2      :525/59.94I
Return3      :NTSC
Return4      :NTSC
```

The camera model name and signal format are displayed at the top of the page (a "-" mark is displayed instead when a camera is not connected).

Reference: Reference signal format and lock status

SDI-1/2: SDI OUTPUT 1/2 connector output format setting

SDI-3/4: SDI OUTPUT 3/4 connector output format setting

Component: Component signal connector output format setting

Return1: Return 1 return signal format setting

Return2: Return 2 return signal format setting

Return3: Return 3 return signal format setting

Return4: Return 4 return signal format setting

CCU hardware diagnostics

```
*Diagnosis*          2/12
DPR  :OK   SDI  :OK
SY   :OK   VIF  :OK
Front Panel : OK
```

The camera Auto Setup category, and the corresponding setup item and status are displayed at the top of the page.

DPR: DPR board status

SDI: SDI board status

SY: SY board status

VIF: VIF board status

Front Panel: HKCU-FP1 CCU Control Panel status (displayed only when the HKCU-FP1 CCU Control Panel is fitted)

Camera system diagnostics

Page 1

```
*System Diag 1/3*    3/12
TRIAX Type Digital
      Cable Connect
      Comp. Auto
      Step 4
Fan Power OK
Timer 96H
CCU Power AC OK
SerialNo 100001
```

TRIAX Type: Triax transmission mode

TRIAX Cable: CCU triax cable connection status

TRIAX Comp.: Triax cable compensation mode selection

TRIAX Step: Triax cable compensation step (internal circuit step display)

Fan Power: CCU power supply fan status

Timer: Elapsed time since power-on

CCU Power: CCU power supply type and status

SerialNo: CCU serial number

Page 2

```
*System Diag 2/3*    4/12
CAMERA Cable Connect
      Data OK
      Power OK
      Tone Detect
REMOTE Cable Connect
      Data OK
      Power OK
```

CAMERA Cable: Camera cable connection status

CAMERA Data: Camera data transmission status

CAMERA Power: Camera power supply status

CAMERA Tone: Camera identification tone detection status

REMOTE Cable: Remote device cable connection status

REMOTE Data: Remote device data transmission status

REMOTE Power: Remote device power supply status

Page 3

```
*System Diag 3/3*    5/12
Intercom
  CCU Private
  CAMERA CH1 ENG
              MIC OFF
              CH2 ENG
              MIC OFF
CAM MIC Gain Local
  CH1 60dB
  CH2 60dB
```

Intercom CCU: CCU intercom selection

Intercom CAMERA CH1: Camera intercom channel 1 selection and microphone status

Intercom CAMERA CH2: Camera intercom channel 2 selection and microphone status

CAM MIC Gain: Camera microphone circuit control selection

CAM MIC CH1: Camera microphone channel 1 amplifier gain

CAM MIC CH2: Camera microphone channel 2 amplifier gain

Network diagnostics

Page 1

```
*Network Diag 1/3*    6/12
MacAddress:000000-000000
Auto Negotiation: ON
Auto MDI/MDIX : ON
Connection Speed:100M
Duplex Mode :HALF
MDI/MDIX :MDIX
Link Status :OK
```

MacAddress: MAC address stored in CCU EEPROM

Auto Negotiation: Auto negotiation setting

Auto MDI/MDIX: Auto-MDIX setting

Connection Speed: Connection speed setting
Duplex Mode: Communication method setting
MDI/MDIX: Communications port wiring configuration selection
Link Status: Network connection status

Page 2

```
*Network Diag 2/3* 7/12
CNS Mode      :BRIGDE
CCU No.       :1
```

CNS Mode: REMOTE and LAN connectors mode setting
CCU No.: CCU number setting

Page 3

```
*Network Diag 3/3* 8/12
IP Address
  0. 0. 0. 0
Subnet Mask
  0. 0. 0. 0
Default Gateway
  0. 0. 0. 0
```

IP Address: CCU IP address setting
Subnet Mask: CCU subnet mask setting
Default Gateway: CCU default gateway setting

CCU SY board diagnostics

```
*SY Diag* 9/12
Reference :HD
HD-SD Delay:Line(90H)
PLD Status :OK
  SY :1.00
  RET :1.00
SY PWR:OK UIF PWR:OK
```

Reference: Reference signal setting
HD-SD Delay: HD to SD delay setting
PLD Status: PLD status
PLD SY: SY-PLD version
PLD RET: RET-PLD version
SY PWR: SY board power supply status
VIF PWR: VIF board power supply status

CCU DPR board diagnostics

```
*DPR Diag* 10/12
HD CB :BAR 16:9(100%)
SD CB :SMPTE
SEQ ON:NPN
PLD Status:OK
  DE-MUX:1.00
  ANALOG:1.00
  POST :1.00
  MAP :1.00
IIC :OK
DPR PWR:OK SDI PWR:OK
```

HD CB: HD color bar setting
SD CB: SD color bar setting
SEQ ON: SEQ ON polarity
PLD Status: PLD status
PLD DE-MUX: DEMUX-PLD version
PLD ANALOG: ANALOG-PLD version
PLD POST: POST-PLD version
PLD MAP: MAP-PLD version
IIC: IIC bus control status
DPR PWR: DPR board power supply status
SDI PWR: SDI board power supply status

Front panel diagnostics

This screen is displayed only when the HKCU-FP1 CCU Control Panel is fitted.

```
*Front Panel Diag* 11/13
Assignable/Custom
SW1 :CAM POWER
SW2 :5600K
VOLUME :SD DTL Level
SW Bright:Low
IIC :OK
```

Assignable/Custom SW1: Function assigned to the SW1 button
Assignable/Custom SW2: Function assigned to the SW2 button
Assignable/Custom VOLUME: Function assigned to the CUSTOM knob
SW Bright: Button lights LED brightness setting
IIC: IIC bus control status

Camera hardware diagnostics

```
*CAMERA Diag* 11/12
ALL BOARD OK
```

Displays the camera hardware status.

ROM Version Information

ROM Version	12/12	
CAMERA	HXC-100	
	1.00	09.01.01
CCU	HXCU-100	
	1.00	09.01.01
REMOTE	RCP-920	
	1.20	09.01.01

CAMERA: Camera model name and ROM version

CCU: CCU model name and ROM version

REMOTE: REMOTE connector device model name and ROM version

Setup Menu

The CCU system and peripheral settings can be modified using a picture monitor connected to the PIX output.

Changing Menu Item Settings

The menu screen is controlled using the knob and levers in the MENU control block on the front panel.

Setting the CANCEL/ENTER lever to the ENTER position and pressing the CONTROL knob perform the same function.

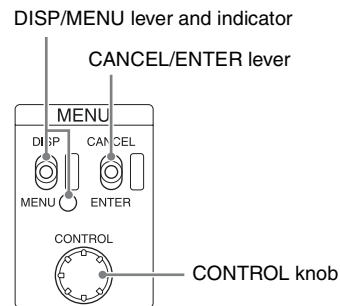

To display a menu page

Set the DISP/MENU lever to the MENU position.

When first powered on, the CCU MENU page is displayed.

To display the CCU MENU page

In menu display mode, turn the CONTROL knob to move the → arrow to TOP in the upper right corner of the menu page, then press the CONTROL knob.

The CCU MENU showing the menu configuration is displayed.

** CCU MENU **
→SYSTEM OPERATION
CCU CONFIGURATION
NETWORK SETTINGS

Menu name	Description
SYSTEM OPERATION	Input/output signal format and system-related settings
CCU CONFIGURATION	CCU configuration settings
NETWORK SETTINGS	Network-related settings

To select an item in the CCU MENU

Turn the CONTROL knob to move the → arrow up/down to the desired menu item, then press the CONTROL knob.

The most recently viewed page in the selected menu is displayed.

To change the displayed page

- 1 Turn the CONTROL knob to move the ➡ arrow to the page number, then press the CONTROL knob. The ➡ arrow changes to a flashing ? question mark.

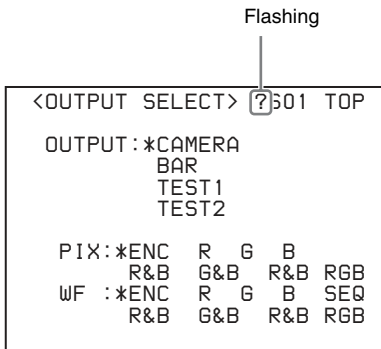

- 2 Turn the CONTROL knob to change the displayed page to the desired page, then press the CONTROL knob. The ? question mark changes back to the ➡ arrow. Items on the page can now be selected and changed.

To change a menu item setting

If a ? question mark is displayed beside the page number, press the CONTROL knob to restore the ➡ arrow. Items on the page can now be selected and changed.

- 1 Turn the CONTROL knob to move the ➡ arrow to the desired item, then press the CONTROL knob. The ➡ arrow changes to a flashing ? question mark.
- 2 Turn the CONTROL knob to change the setting.
 - To cancel a changed setting**
Set the CANCEL/ENTER lever to the CANCEL position before pressing the CONTROL knob. The item is restored to its current setting.
 - To suspend menu changes**
Set the DISP/MENU lever to the MENU position to exit the menu screen.
The DISP/MENU lever can be set to the MENU position again to restart the operation.
- 3 Press the CONTROL knob. The ? question mark changes back to the ➡ arrow, and the item setting is registered.
- 4 Repeat steps 1 to 3 to change other settings on the same page.

To enter a character string

Some menu items require a character string input. Moving the ➡ arrow to an item with a character string input and pressing the CONTROL knob displays a rectangular cursor and a list of selectable characters. Turning the CONTROL knob moves the cursor between characters. The following menu item has character strings:

- CCU CONFIGURATION menu → <BAR CHARACTER> page → BAR CHARACTER

- 1 Move the text cursor to the input position, then press the CONTROL knob. A second cursor is displayed in the character list.
- 2 Turn the CONTROL knob to move the cursor to the desired character, then press the CONTROL knob. Repeat steps 1 and 2 to enter other characters.
 - Select INS to insert a space character at the cursor position.
 - Select DEL to delete the character at the cursor position.
 - Select RET to return to step 1 without changing the string.
 - Entering the maximum number of characters (up to the right edge) moves the cursor to ESC on the lower right of the character list.

- 3 Turn the CONTROL knob to move the cursor to END, then press the CONTROL knob. The new input string is registered.
 - To cancel the character string setting**
Turn the CONTROL knob to move the cursor to ESC, then press the CONTROL knob.

To exit the menu display

In menu display mode, set the DISP/MENU lever to the MENU position.

Menu List

Note

The following conventions are used in the menu list table.

Settings column values (e.g. **ON**, **OFF**, **0**): Default settings

ENTER to execute: Press the CONTROL knob or move the CANCEL/ENTER lever to the ENTER position to execute.

SYSTEM OPERATION menu

Page name Page No.	Item	Settings
<OUTPUT SELECT> S01	OUTPUT Output signal selection	CAMERA , BAR, TEST1, TEST2 TEST1 and TEST2 are not selectable if there is no communication with the camera.
	PIX PIX connector output signal selection	ENC , R, G, B, R&G, G&B, R&B, RGB
	WF WF connector output signal selection	ENC , R, G, B, SEQ, R&G, G&B, R&B, RGB
<GENLOCK PHASE> S02	REFERENCE	(NONE), (EXT IN) Reference signal input status (read only)
	GENLOCK	HD, SD (OK), (NG) External reference signal lock mode selection, lock status, and signal format (OK): Locked (NG): Unlocked
		External reference signal format Displayed only when a reference signal is present (read only)
	Reference signal lock phase adjustments	
	H STEP	When GENLOCK is HD: -3.01 to 3.45 μ s 0.00 When GENLOCK is SD: -8.29 to 9.48 μ s 0.00
	COARSE	-99 to 99 0
	SC PHASE	0 to 359
	V PHASE	0 to 7
	SYNC OUT	HD SYNC, SD SYNC SYNC connector output signal selection

Page name Page No.	Item	Settings
<MULTI FORMAT> S03	FREQUENCY Operating frequency selection	1.001, 1.000
	HD	Note The default setting is different among the sales areas. United States and Canada: 1.001 Other areas: 1.000
	SD	(525 NTSC), (625 PAL) (Read only) When FREQUENCY HD is 1.001: (525 NTSC) When FREQUENCY HD is 1.000: (625 PAL) Note The default setting is different among the sales areas. United States and Canada: (525 NTSC) Other areas: (625 PAL)
	CAMERA FORMAT Transmission format selection	When FREQUENCY HD is 1.001: 1080/59.94i, 720/59.94P When FREQUENCY HD is 1.000: 1080/50i, 720/50P Note The default setting is different among the sales areas. United States and Canada: 1080/59.94i Other areas: 1080/50i

Page name Page No.	Item	Settings
<OUTPUT FORMAT> S04	SLOT NO	
	1-1&2 SDI OUTPUT 1/2 connector output format selection Sequence of format options: 1: HD 2: SD	When CAMERA FORMAT is 1080/59.94i: 1080/59.94i, 525/59.94i When CAMERA FORMAT is 720/59.94P: 720/59.94P, 525/59.94i When CAMERA FORMAT is 1080/50i: 1080/50i, 625/50i When CAMERA FORMAT is 720/50P: 720/50P, 625/50i Note The default setting is different among the sales areas. United States and Canada: 1080/59.94i Other areas: 1080/50i
	3&4 SDI OUTPUT 3/4 connector output format selection Sequence of format options: 1: HD 2: SD	When CAMERA FORMAT is 1080/59.94i: M1080/59.94i, M525/59.94i When CAMERA FORMAT is 720/59.94P: M720/59.94P, M525/59.94i When CAMERA FORMAT is 1080/50i: M1080/50i, M625/50i When CAMERA FORMAT is 720/50P: M720/50P, M625/50i Note The default setting is different among the sales areas. United States and Canada: M525/59.94i Other areas: M625/50i
COMPONENT Component signal connector output format selection	HD RGB, HD YPbPr, SD RGB, SD YCD	
HD-SD DELAY HD signal to SD signal delay mode selection	When CAMERA FORMAT is 1080 system format: 0-Delay , Line (90H), Frame (1F) When CAMERA FORMAT is 720 system format: 0-Delay, Line (120H), Frame (2F) When GENLOCK is HD: 0 to -71.1 μs When GENLOCK is SD: 0 to -51.7 μs	

Page name Page No.	Item	Settings
<SD ASPECT> S05	SD ASPECT SD output aspect selection	SQUEEZE, EDGE CROP , LETTER BOX
	SD LB SEL LETTER BOX aspect ratio selection	16:9 , 15:9, 14:9, 13:9
	H POSITION Horizontal position setting	-99 to 99, (-99) to (99) 0 () displayed when SD ASPECT is SQUEEZE or LETTER BOX (read only)
	CENTER Horizontal centering selection	ON , OFF, (ON), (OFF) () displayed when SD ASPECT is SQUEEZE or LETTER BOX (read only)
	V POSITION Vertical position setting	-99 to 99, (-99) to (99) (0) () displayed when SD ASPECT is SQUEEZE or EDGE CROP (read only)
	CENTER Vertical centering selection	ON, OFF, (ON) , (OFF) () displayed when SD ASPECT is SQUEEZE or EDGE CROP (read only)
	H INTERP Down converter horizontal filter selection	A , B, C, D, E
	V INTERP Down converter vertical filter selection	A , B, C, D, E

Page name Page No.	Item	Settings
<RETURN FORMAT> S06	RET1	When CAMERA FORMAT is 1080/59.94i: 1080/59.94i , 525/59.94i, NTSC When CAMERA FORMAT is 720/59.94P: 720/59.94P, 525/59.94i, NTSC When CAMERA FORMAT is 1080/50i: 1080/50i, 625/50i, PAL When CAMERA FORMAT is 720/50P: 720/50P, 625/50i, PAL SQUEEZE, EDGE CROP, LETTER BOX Not displayed for HD SDI signals 16:9, 15:9, 14:9, 13:9 Not displayed for HD SDI signals
	RET2	When CAMERA FORMAT is 1080/59.94i: 1080/59.94i , 525/59.94i, NTSC When CAMERA FORMAT is 720/59.94P: 720/59.94P, 525/59.94i, NTSC When CAMERA FORMAT is 1080/50i: 1080/50i, 625/50i, PAL When CAMERA FORMAT is 720/50P: 720/50P, 625/50i, PAL SQUEEZE, EDGE CROP, LETTER BOX Not displayed for HD SDI signals 16:9, 15:9, 14:9, 13:9 Not displayed for HD SDI signals
	RET3	When CAMERA FORMAT is 1080/59.94i: 1080/59.94i, 525/59.94i, NTSC When CAMERA FORMAT is 720/59.94P: 720/59.94P, 525/59.94i, NTSC When CAMERA FORMAT is 1080/50i: 1080/50i, 625/50i, PAL When CAMERA FORMAT is 720/50P: 720/50P, 625/50i, PAL SQUEEZE, EDGE CROP, LETTER BOX Not displayed for HD SDI signals 16:9, 15:9, 14:9, 13:9 Not displayed for HD SDI signals

Page name Page No.	Item	Settings
<RETURN FORMAT> S06	RET4	When CAMERA FORMAT is 1080/59.94i: 1080/59.94i, 525/59.94i, NTSC When CAMERA FORMAT is 720/59.94P: 720/59.94P, 525/59.94i, NTSC When CAMERA FORMAT is 1080/50i: 1080/50i, 625/50i, PAL When CAMERA FORMAT is 720/50P: 720/50P, 625/50i, PAL SQUEEZE, EDGE CROP, LETTER BOX Not displayed for HD SDI signals 16:9, 15:9, 14:9, 13:9 Not displayed for HD SDI signals
	SD RET ASPECT	AUTO, MANUAL AUTO: Automatically follows the SD output aspect setting MANUAL: Set manually, independent of SD output aspect setting

CCU CONFIGURATION menu

Page name Page No.	Item	Settings
<COLOR BAR> C01	HD BAR HD output color bar settings	
	SEL	BAR 16:9 (100%) , BAR 16:9 (75%), SMPTE 16:9 (BLACK), SMPTE 16:9 (-I/Q), BAR 4:3 (100%), BAR 4:3 (75%), SMPTE 4:3 (BLACK), SMPTE 4:3 (-I/Q), MF-ARIB (75%), MF-ARIB (100%), MF-ARIB (+I), MF-SMPTE (-I,Q), MF-SMPTE (75%,Q), MF-SMPTE (100%,Q), MF-SMPTE (+I,Q), HD-CUSTOM, SDI CHECK FIELD, Y -RAMP, Y/C-RAMP, HD-CUSTOM2
	MF CB	MODIFY , EVEN
	SLOPE	WIDE , NARROW
	SD BAR SD output color bar setting	For NTSC: SMPTE , EIA, FULL, 95%, NTSC100%, Y/C-RAMP, Y -RAMP, DISABLE For PAL: SMPTE , EIA, EBU, 95%, PAL100%, Y/C-RAMP, Y -RAMP, DISABLE DISABLE: Down conversion output of HD color bar signal
	BAR CHARA Character superimposed on color bar signal	ON, OFF
	GRAY	ON , OFF ON: Gray screen output when camera power supply is off OFF: Color bar signal output when camera power supply is off
<BAR CHARACTER> C02	BAR CHARACTER	Settings for strings 1 to 11 that are superimposed on the color bar signal
	<ALL CLEAR>	ENTER to execute Execute to clear all character strings
<MONITOR 1> C03	CHARACTER	
	WHITE LEVEL	0.0 to 107.0% 71.5
	BLACK LEVEL	0.0 to 107.0%
	PIX CHARACTER	
	WHITE LEVEL	75.0 to 107.0%
	BLACK LEVEL	0.0 to 25.0%

Page name Page No.	Item	Settings
<MONITOR 2> C04	LEVEL GATE	---, 1&2, 1, 2, OFF ---: Displayed when camera not connected, video output not set to CAMERA, or video output is set to CAMERA and GATE MARKER is ON (read only)
	Y LEVEL1	0 to 108% 49 61
	Level gate 1 minimum and maximum detection levels and zebra range settings	-99 to 99 -25
	Y LEVEL2	0 to 108% 74 108
	Level gate 2 minimum and maximum detection levels and zebra range settings	-99 to 99 -25
	GATE MARKER	---, ON, OFF Gate signal display on/off and signal level setting ---: Displayed when camera not connected (read only)
		-99 to 99 0
	MODULATION	---, ON, OFF 4:3 aspect ratio mask function on/off when EDGE CROP is ON, and mask video level setting ---: Displayed when camera not connected (read only)
		-99 to 99 0
	MARKER	ON, OFF Marker signal on/off and superimposed signal selection 4:3 , 13:9, 14:9, EU VISTA, VISTA, CINEMA, FOLLOW DC

Page name Page No.	Item	Settings
<MIC/AUDIO> C05	CAM MIC GAIN	(REMOTE), (LOCAL) (REMOTE): MIC REMOTE source (LOCAL): Not MIC REMOTE source
	CH1	---, 20, 30, 40, 50, 60 dB ---: Displayed when camera not connected (read only)
	CH2	---, 20, 30, 40, 50, 60 dB ---: Displayed when camera not connected (read only)
	MIC REMOTE	MIC 1&2 , MIC 1.2
	MIC REMOTE gain control method	MIC 1&2: MIC 1, 2 common gain control MIC 1.2: MIC 1, 2 independent gain control
	MIC OUT	
	DELAY	0 to 3328 Fs
	MIC OUT 1,2 delay setting	
	MIC1 LEVEL	-20, 0 dBu
	MIC2 LEVEL	-20, 0 dBu
<INCOM/PGM> C06	SYSTEM INTERFACE	
	ENGINEER	CLEAR COM, RTS, (4W) Engineer line intercom system selection (4W): Displayed when the internal hardware switch is set to 4-Wire (read only)
	PRODUCER	CLEAR COM, RTS, (4W) Producer line intercom system selection (4W): Displayed when the internal hardware switch is set to 4-Wire (read only)
	PGM1 LEVEL	-20, 0 , +4 dBu
	PGM2 LEVEL	-20, 0 , +4 dBu

Page name Page No.	Item	Settings
<FRONT INCOM> C07	CCU front panel MIC/PGM switch position (read only)	(MIC ON), (OFF), (PGM ON)
	CCU front panel INTERCOM switch position (read only)	(PRIVATE), (PROD), (ENG)
	INCOM MIC	CARBON, ECM, DYNAMIC
	Headset microphone type connected to INTERCOM on the front panel	CARBON: Carbon microphone (power supply, 20 dB gain) ECM: Electret condenser microphone (power supply, 40 dB gain) DYNAMIC: Dynamic microphone (no power supply, 60 dB gain)
	MIC TYPE	BALANCE, UNBALANCE
	Headset microphone type connected to INTERCOM on the front panel	BALANCE: Balanced microphone UNBALANCE: Unbalanced microphone
	MIC GAIN	-6dB, 0dB , +6dB
	Input gain setting	
	SIDE TONE	0 to 99 50
	PGM MIX	OFF , INCOM+PGM, L-INCOM/R-PGM
	PGM SEL	PGM1 , PGM2, PGM1+PGM2
	PGM1 LVL	0 to 99 50
	PGM2 LVL	0 to 99 50
	<PROMPTER> C08	MODE
Video resolution mode switch		NORMAL: Color picture transmitted as-is in standard resolution with delay of approximately 5 frames LOW LATENCY: SD B&W picture transmitted as low resolution simplified images on VBS Y only with delay less than 1 frame
TRANSFER		(VBS) , (VBS Y Only) (VBS): Displayed when MODE is NORMAL (read only) (VBS Y Only): Displayed when MODE is LOW LATENCY (read only)

Page name Page No.	Item	Settings
<VIDEO SETUP> C09	SETUP	ON, OFF , -- --: Displayed when format is PAL (read only)
	Q FILTER	NARROW , WIDE, --
	Q FILTER bandwidth setting	--: Displayed when format is PAL (read only)
	SD G/Y SYNC	ON , OFF
	SD RGB component signal Gch-SYNC or SD YCD component signal Ych-SYNC on/off	
	WF SYNC	ON , OFF
	WF signal SYNC on/off	
<VIDEO ADJUST> C10	VBS	
	LEVEL	-99 to 99 0
	CHROMA	-99 to 99 0
	PIX	
	LEVEL	-99 to 99 0
	CHROMA	-99 to 99 0
	WF	
	LEVEL	-99 to 99 0
	CHROMA	-99 to 99 0
	G/Y LEVEL	-99 to 99 0
	B/B-Y LEVEL	-99 to 99 0
R/R-Y LEVEL	-99 to 99 0	

Page name Page No.	Item	Settings
<MENU SETTINGS> C11	RESUME	ON , OFF
	In menu mode, resume display of previously displayed page function	
	RE DIRECTION	
	CONTROL knob operating mode settings	
	CATEGORY	STD , RVS
		STD: CONTROL knob clockwise rotation moves the CCU MENU ➡ arrow down RVS: CONTROL knob counterclockwise rotation moves the CCU MENU ➡ arrow down
	PAGE	STD , RVS
		STD: CONTROL knob clockwise rotation displays the next page in the menu RVS: CONTROL knob counterclockwise rotation displays the next page in the menu
	ITEM	STD , RVS
		STD: CONTROL knob clockwise rotation moves the ➡ arrow down to the next item on the page RVS: CONTROL knob counterclockwise rotation moves the ➡ arrow down to the next item on the page
	DATA	STD , RVS
		STD: CONTROL knob clockwise rotation selects the next data option RVS: CONTROL knob counterclockwise rotation selects the next data option

Page name Page No.	Item	Settings
<DISPLAY> C12	MESSAGE	ALL , WARNING, OFF ALL: Displays all messages WARNING: Displays system warning messages and menu control messages OFF: Displays only menu control messages
Camera messages and switch settings on/off. Displayed on the camera diagnostics screen.	ALARM JUMP	ON, OFF In menu mode, jump to display page if an error occurs function
	MASTER GAIN	ON , OFF
	ECS/SHUTTER	ON , OFF
	ND FILTER	ON , OFF
	IRIS	ON , OFF
	EXTENDER	ON , OFF
<DATE> C13	DATE/TIME	20YY/MM/DD hh:mm Date and time settings Time displayed in 24-hour format
	TIME ZONE	hh:mm Time zone setting -11h59m to +11h59m
<OTHERS> C14	REAR PREVIEW	MOMENTARY , TOGGLE MOMENTARY: Display preview while PREVIEW button on REMOTE device is pressed TOGGLE: Toggle preview on/off when the PREVIEW button on REMOTE device is pressed
	CAM POWER REMOTE	NORMAL , BACKUP NORMAL: When CCU power is applied, power is supplied to camera BACKUP: When CCU power is applied, camera supply remains in state when CCU power was last turned off.

Page name Page No.	Item	Settings
<FRONT PANEL 1> C15	ASSIGNABLE/CUSTOM SWITCH1	NOT ASSIGN , GAMMA OFF, HD DTL OFF, SD DTL OFF, BLK GAMMA, KNEE OFF, AUTO KNEE, 5600K, CAM POWER NOT ASSIGN: Not assigned (indicator always off) GAMMA OFF: Gamma off when indicator on HD DTL OFF: HD detail off when indicator on SD DTL OFF: SD detail off when indicator on BLK GAMMA: Black gamma on when indicator on KNEE OFF: Knee off when indicator on AUTO KNEE: Auto knee on when indicator on 5600K: 5600K on when indicator on CAM POWER: Camera power on when indicator on
Displayed only when the HKCU-FP1 CCU Control Panel is fitted	HKCU-FP1 CCU Control Panel SW1 button assignment	
	SWITCH2	NOT ASSIGN , GAMMA OFF, HD DTL OFF, SD DTL OFF, BLK GAMMA, KNEE OFF, AUTO KNEE, 5600K, CAM POWER NOT ASSIGN: Not assigned (indicator always off) GAMMA OFF: Gamma off when indicator on HD DTL OFF: HD detail off when indicator on SD DTL OFF: SD detail off when indicator on BLK GAMMA: Black gamma on when indicator on KNEE OFF: Knee off when indicator on AUTO KNEE: Auto knee on when indicator on 5600K: 5600K on when indicator on CAM POWER: Camera power on when indicator on
	HKCU-FP1 CCU Control Panel SW2 button assignment	

Page name Page No.	Item	Settings
<FRONT PANEL 1> C15 Displayed only when the HKCU-FP1 CCU Control Panel is fitted	VOLUME HKCU-FP1 CCU Control Panel CUSTOM knob assignment	NOT ASSIGN , HD GAMMA, SD GAMMA, HD DTL LEVEL, SD DTL LEVEL, BLK GAMMA NOT ASSIGN: Not assigned (knob deactivated) HD GAMMA: HD M-gamma setting SD GAMMA: SD M-gamma setting HD DTL LEVEL: HD detail level setting SD DTL LEVEL: SD detail level setting BLK GAMMA: Black gamma setting
VOLUME MODE		
	IRIS IRIS knob operating mode	REL, ABS REL: Relative value mode ABS: Absolute value mode
	M BLACK MASTER BLACK knob operating mode	REL, ABS REL: Relative value mode ABS: Absolute value mode
	R/B BLACK BLACK/FLARE knob function and operating mode	REL/BLACK, ABS/BLACK, REL/FLARE, ABS/FLARE REL/BLACK: BLACK (relative value mode) ABS/BLACK: BLACK (absolute value mode) REL/FLARE: FLARE (relative value mode) ABS/FLARE: FLARE (absolute value mode)
	R/B WHITE WHITE knob operating mode	REL, ABS REL: Relative value mode ABS: Absolute value mode

Page name Page No.	Item	Settings
<FRONT PANEL 2> C16 Displayed only when the HKCU-FP1 CCU Control Panel is fitted	VOLUME REL COEFF IRIS Relative coefficient when the IRIS knob is set to relative value mode	1/1, 1/2 , 1/4 1/1: Variable range roughly 100% of total variation 1/2: Variable range roughly 50% of total variation 1/4: Variable range roughly 25% of total variation
	M BLACK Relative coefficient when the MASTER BLACK knob is set to relative value mode	1/1, 1/2, 1/4 1/1: Variable range roughly 100% of total variation 1/2: Variable range roughly 50% of total variation 1/4: Variable range roughly 25% of total variation
	R/B BLACK Relative coefficient when the BLACK/FLARE knob is set to relative value mode	1/1, 1/2 , 1/4, (FLARE) 1/1: Variable range roughly 100% of total variation 1/2: Variable range roughly 50% of total variation 1/4: Variable range roughly 25% of total variation (FLARE): Displayed when the BLACK/FLARE knob is assigned to the FLARE function (read only)
	R/B WHITE Relative coefficient selection when the WHITE knob is set to relative value mode	1/1, 1/2, 1/4 1/1: Variable range roughly 100% of total variation 1/2: Variable range roughly 50% of total variation 1/4: Variable range roughly 25% of total variation
	CUSTOM Relative coefficient when the CUSTOM knob is set to relative value mode	1/1, 1/2 , 1/4 1/1: Variable range roughly 100% of total variation 1/2: Variable range roughly 50% of total variation 1/4: Variable range roughly 25% of total variation
	SW BRIGHT Front panel button lights LED brightness	NORMAL , LOW

NETWORK SETTINGS menu

Page name Page No.	Item	Settings
<TCP/IP SETTING> N01	IP ADDRESS	0.0.0.0 to 255.255.255.255
	SUBNET MASK	0.0.0.0 to 255.255.255.255
	DEFAULT GATEWAY	0.0.0.0 to 255.255.255.255
	SET	ENTER to execute A "SET OK?" confirmation message is displayed. Press ENTER again to confirm the change.
<LAN SETTINGS> N02	AUTO NEGOTIATION	ON , OFF
	AUTO MDI/MDIX	ON , OFF
	CONNECTION SPEED	10M, 100M
	DUPLEX MODE	HALF, FULL
	MDI/MDIX	MDI , MDIX
	LINK CONDITION	(DOWN), (UP) (Read only)
SET	ENTER to execute A "SET OK?" confirmation message is displayed. Press ENTER again to confirm the change.	
<CNS SETTINGS> N03	CNS MODE	LEGACY , BRIDGE
	Network connection mode selection	LEGACY: External controller connected using CCA-5 cable only BRIDGE: External controller connected using point-to-point LAN cable
	CCU NO	Default: 0 1 to 96, A to Z
<NETWORK RESET> N04	ALL RESET	ENTER to execute A "NET SETTINGS RESET OK?" message is displayed. Press ENTER again to reset NETWORK SETTINGS menu items to factory default values.

Appendix

Notes on Use

Use and storage locations

Avoid using or storing the unit in the following places:

- Where it is subject to extremes of temperature (operating temperature: +5 to +40 °C (41 to 104 °F)). Note that in summer the temperature in a car with the windows closed can reach 50 °C (122 °F).
- Very damp or dusty places.
- Where rain is likely to reach the unit.
- Places subject to severe vibration.
- Near strong magnetic fields.
- Near transmitting stations generating strong radio waves.

Avoid violent impacts

Dropping the unit, or otherwise imparting a violent shock to it, is likely to cause it to malfunction.

Do not cover with cloth

While the unit is in operation, do not cover it with a cloth or other material. This can cause the temperature to rise, leading to a malfunction.

After use

Set the POWER switch on the CCU to the OFF position.

Care

If the body or panels of the unit become dirty, wipe them with a dry cloth. For severe dirt, use a soft cloth steeped in a small amount of neutral detergent, then wipe dry. Do not use volatile solvents such as alcohol or thinners, as these may damage the finish.

Digital Triax Transmission

Digital transmission between camera and CCU with powerful error correction function built-in. However, some errors, for example errors due to external noise in long-distance transmission, may be corrected by partial image interpolation of images in frame store.

In digital triax transmission, the following video delay in transmission may occur.

- The video delay in transmission between the camera and the CCU is approximately 9 to 12 ms.
- A delay of about 1 frame occurs on the viewfinder display if a camera image is sent back from the CCU to the camera as a return signal.
- A delay of about 5 frames occurs on the teleprompter video in standard mode (standard mode or low-latency mode using simplified images can be selected on the CCU).
- An appropriate delay is applied to the MIC 1 and 2 audio signals from the CCU to match the video delay.

- A certain time is required for the video signal transmitted between the camera and the CCU to stabilize after power is applied. This is not a malfunction.

Triax transmission distances

The maximum and minimum transmission distances allowed for triax cable connections are shown in the table below. The distances may vary according to the conditions, such as cable degradation.

Allowable transmission range when using triax cables with the following characteristics:

3.8 to 45.6 dB at 100 MHz (including the connector loss)

Cable		Max. distance	Min. distance
Fujikura	8.5 mm dia.	600 m (1969 ft.)	50 m (164 ft.)
Fujikura	14.5 mm dia.	1200 m (3937 ft.)	100 m (328 ft.)
Belden 9232	13.2 mm dia.	850 m (2789 ft.)	75 m (246 ft.)

Error Messages

When an error is detected in the CCU or the camera, the ALARM indicator turns on and an error message is displayed on the CCU.

Error message	Indication
CCU: GEN LOCK NG	External reference sync error
CCU: DPR NG	Front DPR board power supply, PLD error
CCU: SDI NG	Rear SDI board power supply error
CCU: PS FAN NG	Power supply block fan error
CCU: PS CABLE SHORT	CAMERA connector triax cable short circuit error
CCU: PS CABLE OPEN	CAMERA connector triax cable open circuit error
CCU: PS RCP PWR SUPPLY NG	Remote control panel (connected to REMOTE connector) power supply error
CCU: VIF NG	Rear VIF board power supply error
CCU: SY NG	Front SY board power supply, PLD error
CCU:RX WARNING	Transmission error between camera and CCU

Return Signal Combinations

The return signals are grouped into the following 16 combinations. The number of the return signal (RET 1 to 4) on the RETURN INPUT connectors is set on the <RETURN FORMAT> page in the SYSTEM OPERATION menu.

SDI 1/3	SDI 2/4	VBS 1/3	VBS 2/4
RET1 HD SDI	RET2 HD SDI	RET3 VBS	RET4 VBS
RET1 HD SDI	RET2 SD SDI	RET3 VBS	RET4 VBS
RET1 SD SDI	RET2 HD SDI	RET3 VBS	RET4 VBS
RET1 SD SDI	RET2 SD SDI	RET3 VBS	RET4 VBS
RET1 HD SDI	RET4 HD SDI	RET3 VBS	RET2 VBS

SDI 1/3	SDI 2/4	VBS 1/3	VBS 2/4
RET1 HD SDI	RET4 SD SDI	RET3 VBS	RET2 VBS
RET1 SD SDI	RET4 HD SDI	RET3 VBS	RET2 VBS
RET1 SD SDI	RET4 SD SDI	RET3 VBS	RET2 VBS
RET3 HD SDI	RET2 HD SDI	RET1 VBS	RET4 VBS
RET3 HD SDI	RET2 SD SDI	RET1 VBS	RET4 VBS
RET3 SD SDI	RET2 HD SDI	RET1 VBS	RET4 VBS
RET3 SD SDI	RET2 SD SDI	RET1 VBS	RET4 VBS
RET3 HD SDI	RET4 HD SDI	RET1 VBS	RET2 VBS
RET3 HD SDI	RET4 SD SDI	RET1 VBS	RET2 VBS
RET3 SD SDI	RET4 HD SDI	RET1 VBS	RET2 VBS
RET3 SD SDI	RET4 SD SDI	RET1 VBS	RET2 VBS

License Declarations

The CCU teleprompter video circuit uses MPEG-2 technology.

MPEG-2 Video Patent Portfolio License

ANY USE OF THIS PRODUCT OTHER THAN CONSUMER PERSONAL USE IN ANY MANNER THAT COMPLIES WITH THE MPEG-2 STANDARD FOR ENCODING VIDEO INFORMATION FOR PACKAGED MEDIA IS EXPRESSLY PROHIBITED WITHOUT A LICENSE UNDER APPLICABLE PATENTS IN THE MPEG-2 PATENT PORTFOLIO, WHICH LICENSE IS AVAILABLE FROM MPEG LA, L.L.C., 250 STEELE STREET, SUITE 300, DENVER, COLORADO 80206.

“PACKAGED MEDIA” means any storage media storing MPEG-2 video information such as DVD movie which are sold/distributed to general consumers. Disc replicators or sellers of the PACKAGED MEDIA need to obtain licenses for their own business from MPEG LA. Please contact MPEG LA for any further information. MPEG LA, L.L.C., 250 STEELE STREET, SUITE 300, DENVER, COLORADO 80206
<http://www.mpegla.com>

Specifications

HXCU-100

General	
Power supply	AC 100 to 240 V, 50/60 Hz
Current consumption	4.5 A (max)
Peak inrush current	(1) Power ON, current probe method: 43 A (240 V) (2) Hot switching inrush current, measured in accordance with European standard EN55103-1: 8 A (230 V)
Operating temperature	5 to 40 °C (41 to 104 °F)
Storage temperature	-20 to +60 °C (-4 to +140 °F)
Weight	Approx. 8.3 kg (18 lb 5 oz)

Input/output connectors	
CAMERA	Triax (1) United States and Canada: Kings type Other areas: Fischer type
INTERCOM/TALLY/PGM	D-sub 25-pin, female (1) <ul style="list-style-type: none"> INCOM (PROD/ENG), 4W/RTS/CC, 0 dBu TALLY (R, G) PGM 2 systems, -20/0/+4 dBu
REMOTE	8-pin multiconnector (1)
TRUNK	D-sub 9-pin, female (1), RS-422A 1 system
LAN	8-pin (1)
Input connectors	
AC IN	(1), AC 100 to 240 V
SERIAL RETURN INPUT	BNC type (2) HD SDI: SMPTE 292M, 0.8 Vp-p, 75 Ω, 1.485/1.4835 Gbps bit rate SD SDI: SMPTE 259M, 270 Mbps bit rate
VBS RETURN INPUT	BNC type (2), 1.0 Vp-p, 75 Ω
REFERENCE INPUT	BNC type (2), loop-through output HD: SMPTE 274M, tri-level sync, 0.6 Vp-p, 75 Ω SD: Black burst (NTSC: 0.286 Vp-p, 75 Ω; PAL: 0.3 Vp-p, 75Ω)
PROMPTER INPUT	BNC type (2), loop-through output, VBS signal, 1.0 Vp-p, 75 Ω, 1 system
MIC REMOTE	D-sub 15-pin, female (1) (JAE DA-C1-J10 series recommended)
Output connectors	
SDI OUT	BNC type (2) HD SDI: SMTPE 292M, 0.8 Vp-p, 75 Ω, 1.485/1.4835 Gbps bit rate SD SDI: SMPTE 259M, 0.8 Vp-p, 75 Ω, 270 Mbps bit rate HD SDI/SD SDI selectable
SDI OUT (MONITOR)	BNC type (2) HD SDI: SMTPE 292M, 0.8 Vp-p, 75 Ω, 1.485/1.4835 Gbps bit rate SD SDI: SMPTE 259M, 0.8 Vp-p, 75 Ω, 270 Mbps bit rate HD SDI/SD SDI selectable
Pr/R/R-Y, Y/G/Y, Pb/B/B-Y	BNC type (3) <ul style="list-style-type: none"> HD component video Y (100% white): 0.7 Vp-p Pr/Pb (75% color bar): 0.7 Vp-p, 75 Ω HD RGB video R/G/B (100% white): 0.7 Vp-p, 75 Ω SD RGB video R/G/B (100% white): 0.7 Vp-p, 75 Ω SD component video Y (100% white): 0.714 Vp-p Pr/Pb (75% color bar): 0.756 Vp-p, 75 Ω
VBS OUT	BNC type (2), VBS 1.0 Vp-p, 75 Ω
PIX OUT	BNC type (1), VBS/R/G/B (VBS 1.0 Vp-p, 75 Ω)

WF OUT	BNC type (1), VBS/R/G/B/SEQ (VBS 1.0 Vp-p, 75 Ω)
SYNC OUT	BNC type (1) HD: BTA-S001A, tri-level sync, 0.6 Vp-p, 75 Ω SD: composite sync, 0.3 Vp-p, 75 Ω HD SYNC/SD SYNC selectable
MIC OUT	XLR 3-pin, male (2), 0/-20 dBu
WF REMOTE	D-sub 15-pin, female (1) (JAE DA-C1-J10 series recommended)
WF MODE	4-pin (1)

Supplied accessories

Number plates (1 set)

Operation manual (1)

Warranty booklet (1)

Optional accessories

HKCU-FP1 CCU Control Panel

United States and Canada: Plug holder B (2-990-242-01)

Other areas: Plug holder C (3-613-640-01)

United States and Canada: Power cord set (1-551-812-XX)

Other areas: Power cord set (1-782-929-XX)

CCA-5-3 (3 m), CCA-5-10 (10 m) connection cables

Extension board

Service manual

Related equipment

HXC-100 HD Color Camera

RCP-700/900 series Remote Control Panel

MSU-900 series Master Setup Unit

Dimensions

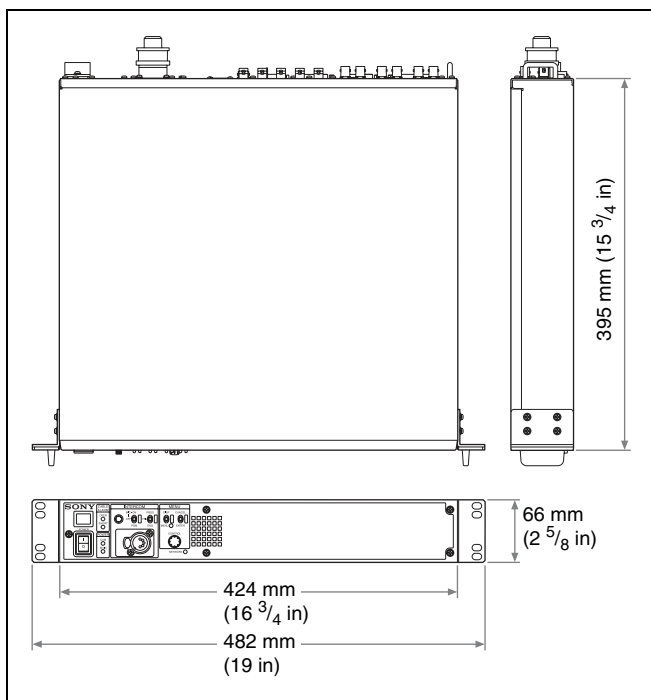

HKCU-FP1 CCU Control Panel (Optional)

Power consumption Approx. 3 W (supplied from the CCU)

Design and specifications are subject to change without notice.

Note

Always verify that the unit is operating properly before use. SONY WILL NOT BE LIABLE FOR DAMAGES OF ANY KIND INCLUDING, BUT NOT LIMITED TO, COMPENSATION OR REIMBURSEMENT ON ACCOUNT OF THE LOSS OF PRESENT OR PROSPECTIVE PROFITS DUE TO FAILURE OF THIS UNIT, EITHER DURING THE WARRANTY PERIOD OR AFTER EXPIRATION OF THE WARRANTY, OR FOR ANY OTHER REASON WHATSOEVER.

<http://www.sony.net/>

Sony Corporation